

SIEMENS



SIMATIC HMI / PC-based Automation

Premium Add-Ons for SIMATIC WinCC

Catalog
ST 80 AO

Edition
2018

siemens.com/simatic-wincc-addons

Related catalogs

SIMATIC HMI / PC-based Automation ST 80/ST PC
Human Machine Interface Systems
PC-based Automation

E86060-K4680-A101-C6-7600



SIMATIC ST 70 N
Products for
Totally Integrated Automation

E86060-K4670-A151-A9-7600



SIMATIC ST 70 N
Products for
Totally Integrated Automation

E86060-K4670-A151-A9-7600



SIMATIC ST PCS 7
SIMATIC PCS 7 Process Control System
Vol. 1: System components

E86060-K4678-A111-C5-7600



Industrial Communication IK PI
SIMATIC NET

E86060-K6710-A101-B8-7600



SITOP KT 10.1
SITOP
Power supply

E86060-K2410-A101-B3-7600

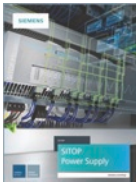

SITRAIN
Training for Industry

www.siemens.com/sitrain



Products for Automation and Drives CA 01
Interactive Catalog
Download

www.siemens.com/ca01download



Industry Mall
Information and Ordering Platform
on the Internet:

www.siemens.com/industrymall



Contact
Your personal contact can be found in our
Contacts Database at:

www.siemens.com/automation-contact



Siemens TIA Selection Tool
for the selection, configuration and ordering of
TIA products and devices

www.siemens.com/tst



SIMATIC HMI



Catalog ST 80 AO · 2018

Supersedes:
Catalog ST 80 / ST PC · 2016

Please refer to the Industry Mall for current updates of this catalog:

www.siemens.com/industrymall

The products contained in this catalog can also be found in the Interactive Catalog CA 01.
Article No.: E86060-D4001-A500-D8-7600

Please contact your local Siemens branch.

© Siemens AG 2018

Introduction	2
Connectivity	
System software	
PM-OPEN IMPORT	3
PM-OPEN EXPORT	4
PM-OPEN TCP/IP	5
Historian CONNECT ALARM	6
TOP Server	7
TOP Server UCON	10
IEC 61850 communication channel	11
Process management	
System software	
PM-CONTROL	12
PM-QUALITY	14
Industry and technology solutions	
ACRON 8 for WinCC	17
7KM PAC3200 library for SIMATIC WinCC	19
Sm@rtLib function library	20
Configuring tools	
DCC Translation Editor	22
Diagnostics and maintenance	
ACC Alarm Control Center	24
System software	
PM-MAINT	26
PM-ANALYZE	28
Appendix	
Conditions of sale and delivery	31



The products and systems described in this catalog are manufactured/distributed under application of a certified quality management system in accordance with DIN EN ISO 9001. The certificate is recognized by all IQNet countries.

Premium Add-ons for SIMATIC WinCC

Introduction

Overview

SIMATIC WinCC (TIA Portal)

SIMATIC WinCC (TIA Portal) is part of a new, integrated engineering concept which offers a uniform engineering environment for programming and configuration of control, visualization and drive solutions.

WinCC (TIA Portal) is the software for all HMI applications ranging from the simplest operation solutions with Basic Panels to SCADA applications on PC-based multi-user systems.

The following versions are currently available:

- SIMATIC WinCC Basic, Comfort, Advanced and Professional

SIMATIC WinCC

SIMATIC WinCC is the SCADA system for scalable process visualization to suit any requirement, from the single-user through to redundant multi-user systems, as well as for plant operation and monitoring over the Internet.

WinCC is also the ideal information hub for IT and business integration, e.g. for the integration of MES and ERP systems. The SIMATIC IT MES system is recommended for scheduling and optimizing complex production processes.

Solutions/add-ons for different sectors and technologies

WinCC stands out for its diversity of applications. The basic system is designed to be independent of any specific technology or industrial sector, to be modular and flexibly expandable, and to permit not only single-user applications in mechanical equipment manufacture, but also complex multi-user solutions, or even distributed systems with several servers and clients in plant engineering.

WinCC applications that are precisely tailored to the requirements of the industrial plant have thus been created for every sector.

These applications are further developed into turnkey add-on products by partners both inside and outside Siemens. If these add-ons meet the general conditions (see "More Information") of the Premium Add-on Program for WinCC, they are promoted to the status of Premium Add-on.

A distinction is made between:

- **WinCC options** are available for a host of expansions to the WinCC basic system and they can be combined freely to meet your requirements. They are subjected to extensive testing with the basic system. As products from Siemens, WinCC options receive central Hotline and Technical Support.
- **WinCC Premium Add-ons** are the add-ons presented in this catalog. They have been developed for solutions in the SCADA area. SIMATIC IT, the MES system from Siemens, is recommended for complex solutions in the MES area. SIMATIC IT with WinCC and PCS 7 offers an integrated solution. Premium add-ons are checked in the Siemens Test Center for compatibility with the basic WinCC system and they receive central Technical Support in the first instance. In addition, the suppliers of the WinCC Premium add-ons must comply with certain general conditions. Some important general conditions are listed under "More Information". Premium add-ons are important application-specific and sector-specific add-on products that supplement WinCC. WinCC Premium add-ons are not products of Siemens Industry Automation and Drive Technologies.

More information

Siemens Premium add-on program for WinCC

The Siemens Premium add-on program sets uniform general conditions for the WinCC Premium add-ons.

Product responsibility, conditions of use

The product responsibility for a Premium Add-on product generally lies with the relevant add-on manufacturer, referred to below as the "Partner".

You can find the address of the partner in the "More Information" section. This permits you to contact the appropriate partner directly. There you can obtain the ordering details and product details, and all sales information relevant to the Premium Add-on product.

Siemens AG accepts no liability and provides no guarantee for the products of external partners.

Support

All Premium add-on products receive central Hotline support Europe-wide (and worldwide in accredited cases), in the first instance from the field-proven Customer Services (CS).

Release support

The product owner partner adapts the Premium add-on products to keep them abreast of the latest version of the WinCC basic system including service pack.

Total discontinuation

If a Premium Add-on product is discontinued by the partner, you will be informed of this via SIMATIC HMI Update.

SIMATIC HMI Update is a newsletter that you can subscribe to from Customer Support.

Conditions of sale and delivery

External partners organize the sale and delivery of their products independently. Their own terms and conditions of business and delivery apply.

Partners' Internet sites

The catalog contains hyperlinks to the web sites of third-party companies.

Siemens is not responsible for the contents of these Web sites, nor does Siemens adopt these Web sites and their contents, as Siemens does not control the linked information and cannot be held responsible for the content and information they contain. You therefore use these links at your own risk.

Pricing information

Pricing information for products in this catalog with article numbers can be obtained via the interactive Catalog CA 01 (CD/DVD), the A&D Mall on the Internet or on request from your local Siemens Partner.

The relevant external partner will provide pricing information for the products without Article No.

Internet catalog

The WinCC Premium add-on Catalog is available exclusively as an online catalog on the Internet and is updated as required.

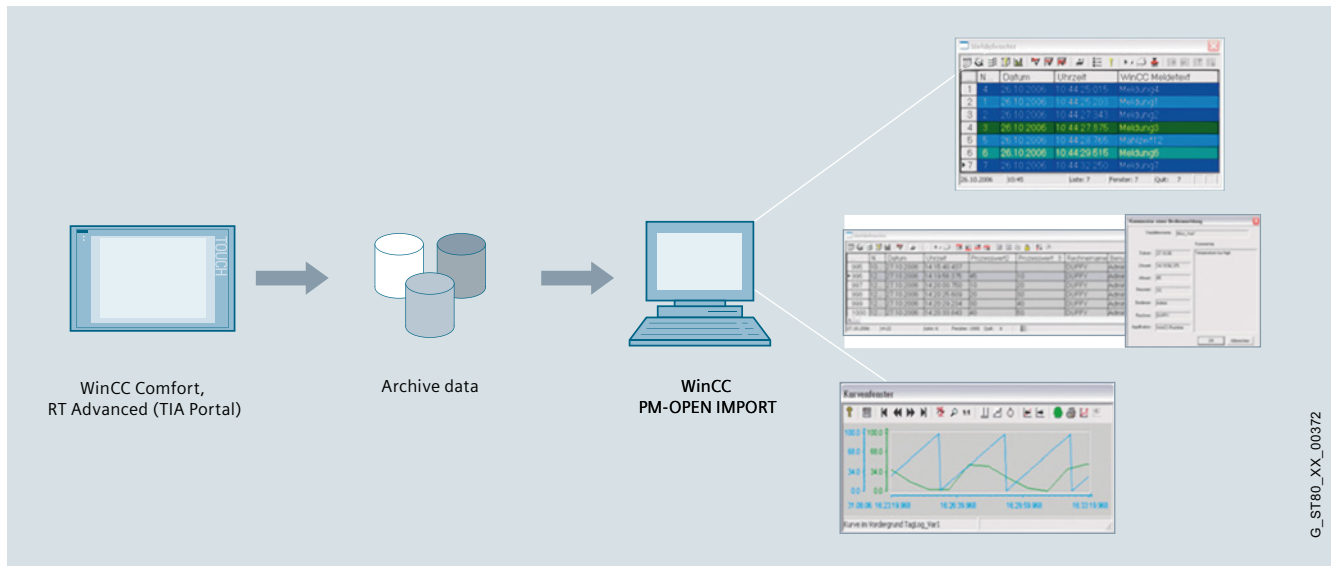
Overview

G_ST80_XX_00372

Process data (tags and messages) and operator actions (audit trail) are archived locally as CSV files on SIMATIC WinCC Comfort Panels or systems with WinCC RT Advanced (TIA Portal).

With PM-OPEN IMPORT, this data can be centrally compiled in chronological order on a higher-level system and also be safely saved there in database format for the long term. The original time stamps are, of course, retained when importing the data into the WinCC system. The standard resources of the WinCC system (WinCC RT Professional (TIA Portal), WinCC, PCS7) are used for display and evaluation.

With PM-OPEN IMPORT, the requirements for the safe, central and long-term archiving of relevant data in the overall automation landscape (from the panel to the higher-level SCADA system) are satisfied as per the guidelines of the Food and Drug Administration (FDA) 21 CFR Part 11 and EU directive 178/2002.

Function

PM-OPEN IMPORT offers the following import functions:

- **Import of WinCC Comfort / WinCC RT Advanced data logs**
The data logs in CSV format are imported into the WinCC Tag Logging or into the WinCC RT Professional archives and can be displayed as a table or as a trend using the standard controls.
- **Import of WinCC Comfort / WinCC RT Advanced alarm logs**
The alarm logs in CSV format are imported into the WinCC Alarm Logging or into the WinCC RT Professional messages and can be displayed as a table using the standard control.

- **Import of WinCC Comfort / WinCC RT Advanced Audit Trails**

The Audit Trail logs in CSV format are imported into the WinCC Alarm Logging or into the WinCC RT Professional messages and can be displayed like WinCC operation messages using the standard control. The data "User name," "Comment" and, if applicable, "Tag name," "Old value" and "New value" are also imported.

Configuration

Only one PM-OPEN IMPORT is required per WinCC PC. There is no software restriction on the number of systems that can be connected. Access on the WinCC side takes place exclusively via Ethernet on a Panel or PC Runtime with WinCC RT Advanced.

Ordering data
Article No.
PM-OPEN IMPORT system software
9AE7114-1SS01-1AA0

Single-user system; can run on interconnected WinCC system

Note:

Additional PM-OPEN IMPORT configurations available on request.

More information

Siemens AG
 Industrial Solutions and Services
 WinCC Competence Center Mannheim

Phone: +49 (0)621 456-3269
 Fax: +49 (0)621 456-3334

E-mail: WinCCAddon.automation@siemens.com

Additional information is available in the Internet at:
<http://www.siemens.com/process-management>

Premium Add-ons for SIMATIC WinCC Connectivity

PM-OPEN EXPORT system software

Overview

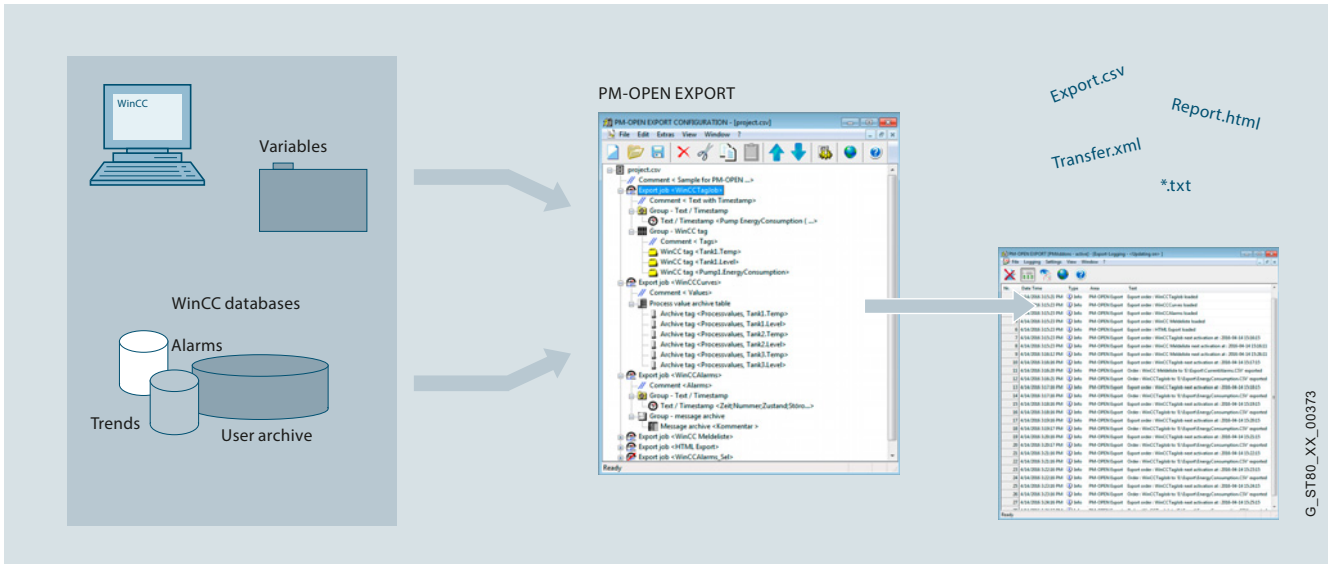

PM-OPEN EXPORT

Flexible and low-cost solution for exporting current process data (tags) and archive data (message archive, process value archive, user archive) from WinCC/PCS7/WinCC RT Professional (TIA Portal) into freely configurable text files (ASCII, CSV, HTML/XML format).

Function

PM-OPEN EXPORT can export to any local memory media or to memory media enabled on the network. For example, it can be used to make data available on a network server for further processing or analysis.

The configured export jobs are processed automatically "in the background". Triggering of the data export can be cyclical, time-controlled, or event-driven.

Flexible and individual structuring of the destination file is a significant benefit. As well as the exported data, the destination file can also contain, for example, static text and time stamps.

Another advantage of PM-OPEN EXPORT is the possibility of using it in redundant WinCC configurations.

Ordering data

PM-OPEN EXPORT system software

Single-user system; can run on interconnected WinCC system

Note:

Additional PM-OPEN EXPORT configurations available on request.

Article No.

9AE7106-1SS01-1AA0

More information

Siemens AG
Industrial Solutions and Services
WinCC Competence Center Mannheim

Phone: +49 (0)621 456-3269
Fax: +49 (0)621 456-3334

E-mail: WinCCAddon.automation@siemens.com

Additional information is available in the Internet at:
<http://www.siemens.com/process-management>

Overview

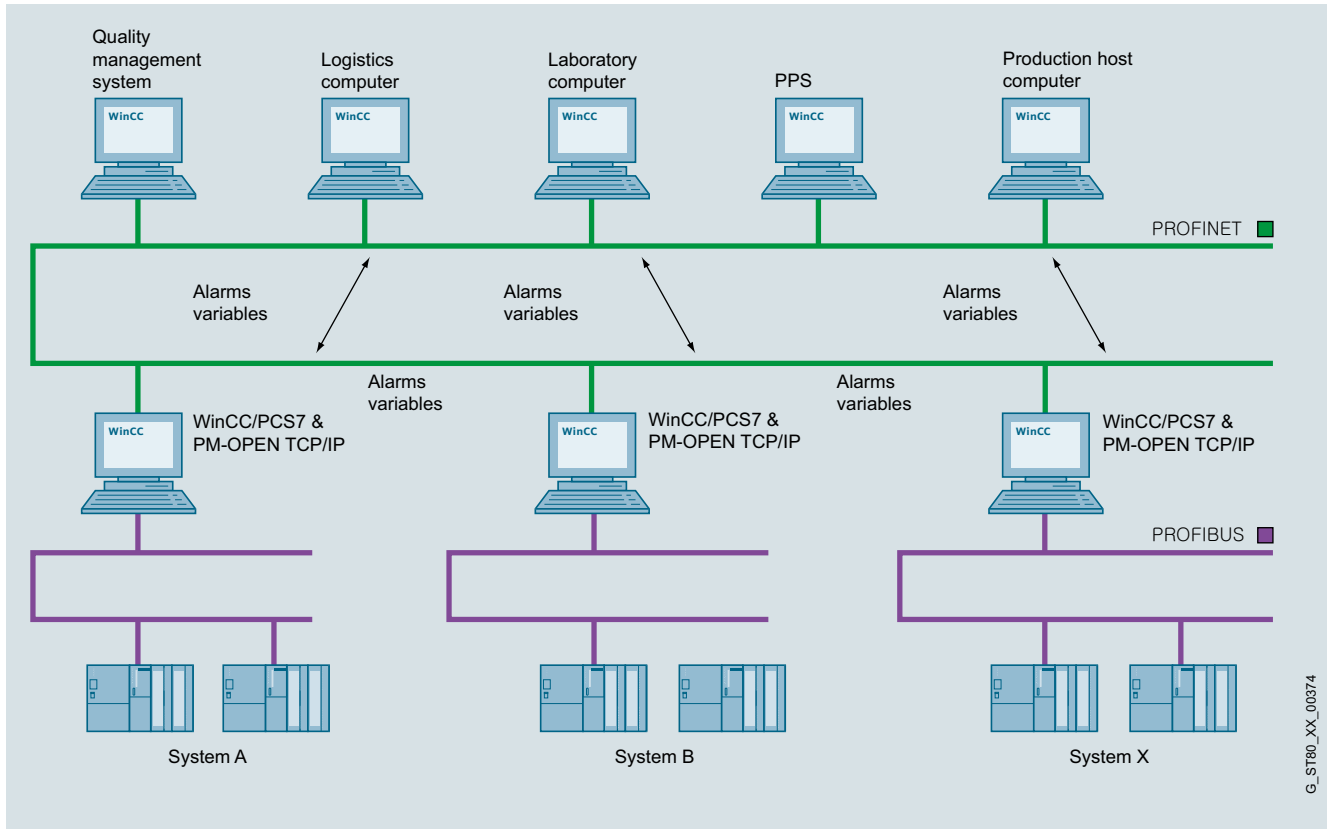

PM-OPEN TCP/IP

Whereas extensive special solutions were previously required for connecting PCs online, PM-OPEN TCP/IP offers a low-cost solution for connecting computer systems (PPS, laboratory, logistics and quality management systems, etc.) with the automation and process control level.

Function

PM-OPEN TCP/IP permits the bidirectional exchange of data (tags, messages) between WinCC/WinCC RT Professional (TIA Portal) and one or more computers (link partners) that communicate using the TCP/IP protocol.

Another use for PM-OPEN TCP/IP is to link several WinCC stations for exchanging tags and messages or acquiring them centrally. In addition, PM-OPEN TCP/IP supports redundant WinCC configurations without any problems.

Thanks to the integration of Visual Basic for Applications (VBA), PM-OPEN TCP/IP offers an ideal development platform for implementing individual IT solutions. SIMATIC WinCC and PM-OPEN TCP/IP thus form a central information hub for local and company-wide IT integration, e.g. connection of the automation level to MES or office applications.

Ordering data

PM-OPEN TCP/IP system software

Single-user system; can run on interconnected WinCC system

Note:

Additional PM-OPEN TCP/IP configurations available on request.

Article No.

9AE7105-1SS01-1AA0

More information

Siemens AG
Industrial Solutions and Services
WinCC Competence Center Mannheim

Phone: +49 (0)621 456-3269
Fax: +49 (0)621 456-3334

E-mail: WinCCAddon.automation@siemens.com

Additional information is available in the Internet at:

<http://www.siemens.com/process-management>

Premium Add-ons for SIMATIC WinCC Connectivity

Historian CONNECT ALARM system software

Overview

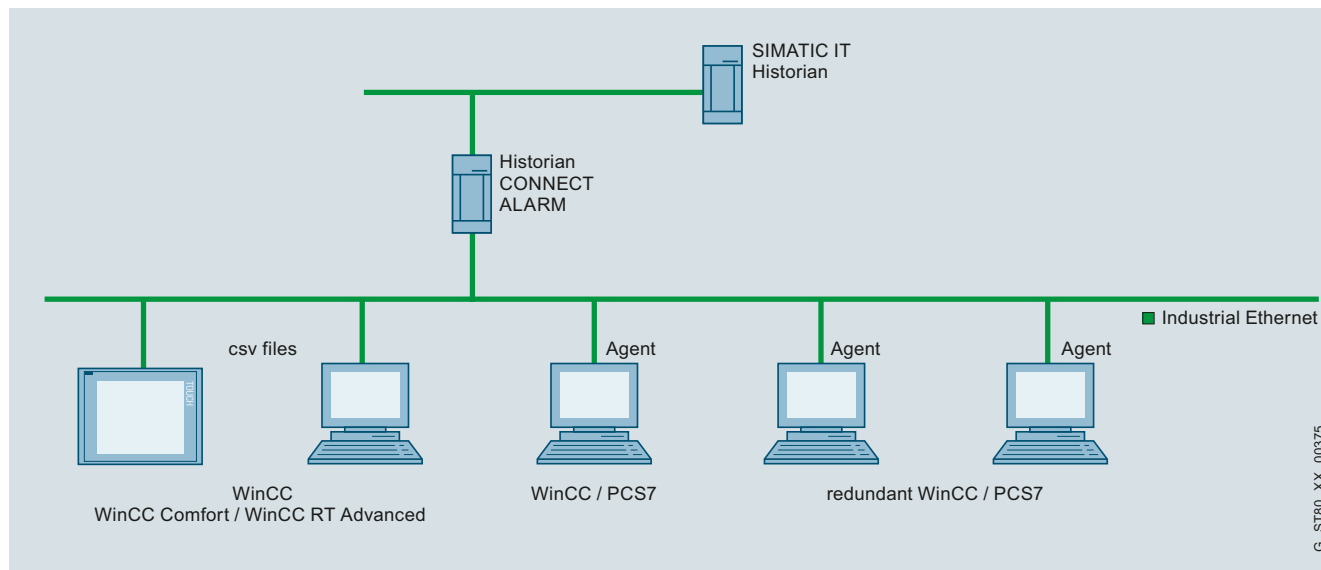

When using SIMATIC IT Historian for long-term archiving and message analysis, it is frequently necessary to transfer messages from different WinCC, PCS7, WinCC RT Professional (TIA Portal), WinCC Comfort, WinCC RT Advanced (TIA Portal) systems or devices.

With the WinCC Add-on Historian CONNECT ALARM as an alarm interface, different data sources can be connected.

Function

Connecting to WinCC systems

Different WinCC stations can be used as the source of the messages. WinCC versions V5, V6 and V7 and WinCC RT Professional (TIA Portal) are supported here.

An agent installed on the WinCC system acquires the messages there and forwards them to the alarm interface using TCP/IP. Assignment of the WinCC message columns to the message columns of the SIMATIC IT alarm filter can be freely configured by the user.

Connection to SIMATIC HMI Comfort Panels

Comfort Panels and WinCC RT Advanced systems are able to store their messages in an archive as a CSV file. The CSV files are copied to the PC of the alarm interface over an Ethernet network, either cyclically or at the end of the batch. For each connected panel, a license is required for the connection.

The alarm interface reads the alarms from the files and enters them into the SIMATIC IT Historian. Assignment of the message columns in the CSV files to the message columns of the SIMATIC IT alarm filter can be freely configured by the user.

Ordering data

Article No.

Historian CONNECT ALARM system software	9AE7115-1SS01-1AA0
Alarm agent for WinCC	9AE7115-2SA01-1AA0
Alarm connection for a panel	9AE7115-3SA01-1AA0

More information

Siemens AG
Industrial Solutions and Services
WinCC Competence Center Mannheim

Phone: +49 (0)621 456-3269
Fax: +49 (0)621 456-3334

E-mail: WinCCAddon.automation@siemens.com

Additional information is available in the Internet at:

<http://www.siemens.com/process-management>

Overview

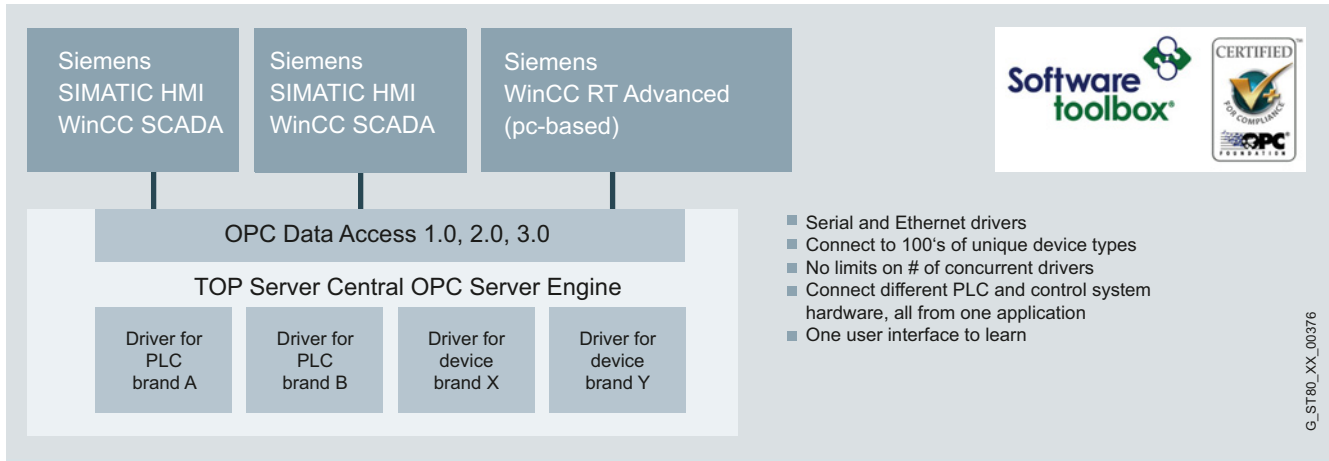

TOP Server

TOP Server OPC Server – extended connectivity for SIMATIC WinCC, WinCC (TIA Portal) and WinCC Runtime Advanced/Professional

The TOP Server OPC Server offer many diverse connection options for users, integrators, and OEMs of SIMATIC HMI such as WinCC SCADA (pc-based Runtime).

TOP Server is a proven OPC data integration platform with over 13,000 installations in more than 110 countries, including many successful applications with more than 100,000 tags.

Benefits

- Allows greater distances between WinCC and field devices
- Lower engineering and integration costs for non-Siemens hardware
- Low training costs since all drivers use the same interface
- Additional benefits when using WinCC as HMI/SCADA
- Winner of the Leverage Award thanks to the "Powered by Kepware" technology in combination with the experience, the support and the Siemens HMI/SCADA know-how of Software Toolbox

Simple configuration

- Point & click, configuration possible without programming expertise
- Includes instructions for WinCC Connectivity – can be connected like any OPC server
- Drag & drop copying of tags and devices
- Tag import/export
- Automatic tag database generation by device or by programming software
- Dynamic tag creation/direct addressing
- Support for changes during runtime
- Configuration password protection available

Premium Add-ons for SIMATIC WinCC Connectivity

TOP Server

Function

Open, based on standards

- OPC interoperability tested in conjunction with WinCC, WinCC (TIA Portal), WinCC Runtime Advanced/Professional
- OPC Certified for OPC DA 2.05a & 3.0 and OPC UA
- Individual OPC interfaces to WinCC for multiple drivers
- Plug-in architecture for adding new device types easily
- Supports Windows XP, Vista, Windows 7, Windows 8, Windows 10, Server 2008, 2008 R2, Server 2012 and Server 2012 R2 additions, as well as Hyper-V and VMware virtualization

Flexible functions

- Mapping of OPC ProgIDs for easy substitution of alternate OPC servers
- Configurable user security policies provide variable access control even down to specific tags
- More than 100 serial and Ethernet device types are supported by more than 70 different drivers
- Suitable for parallel and multicore processor architectures
- Integrated support for serial Ethernet conversion/terminal server in order to make existing older hardware Internet-capable
- Telephone modems are supported by most serial drivers
- Comprehensive configuration options for many drivers for more flexibility in comparison to conventional HMI/SCADA drivers
- Redundancy support on the media and device level
- Innovative plug-in of tags

Troubleshooting and commissioning tools

- The OPC Quick Client Test Tool allows quick testing in the plant and in the laboratory
- The log diagnostics show all of the data transferred between TOP servers and devices. Sending of e-mails is possible. The data is identical to the data that can be recorded on-site.
- The OPC diagnostics aid in the quick solving of problems between the OPC client and server
- Log diagnostics data can be saved over an extended period for later analysis of transmission errors which occur in the absence of monitoring personnel

Functions for vertical industries

- The Oil & Gas Suite provides industry-specific drivers and functions
- The EFM Suite for exporting historical EFM data for Flow-Cal (for Gas and Liquids), Quorum PGAS, and generic CSV and ODBC formats
- The Building Automation Suite including BacNet
- The Power/Utilities Suite including IEC61850, DNP, Modbus, and others
- The IT&Infrastructure Suite including SNMP Agent & Master, Modbus, System Monitor, and others
- The General Manufacturing Suite with more than 50 drivers for the most commonly used control systems

Straightforward licensing

- Licensing by means of a software key, including license transfer utility. Also available via the Internet. Optional hardware key (extra charge).
- The license is valid per computer for an unlimited number of field devices, tags, or clients

TOP Server drivers list

- AB Bulletin 900 Temp Controllers
- AB Bulletin 1609 UPS
- ABB Totalflow serial
- AB/Rockwell Suite: AB DF1 Serial (Full & Half Duplex), AB DH+/DH-485, MicroLogix, PLC5, SLC5/05, ControlLogix, CompactLogix, Flexlogix Ethernet, including 1761-NET-ENI (no RS Linx required!)
- Advanced Simulator
- Alstom Redundant Ethernet
- Analog Devices 6B
- Aromat Serial & Ethernet
- Automation Direct Serial DirectNet, K-Sequence & Ethernet (ECOM & EBC)
- Bailey Fisher & PorterMicroDCI
- Bacnet
- Beckhoff TwinCAT Ethernet
- Bristol/IP Ethernet (BSAP)
- Busware Ethernet I/O
- Contrex CX1000 & M Series
- Custom Interface Driver (CID)
- Cutler Hammer D50/100 & ELC Ethernet
- Danfoss AKC55 Serial
- DataForth IsoLynx
- DDE Server to OPC Client Bridge (converts DDE Server to OPC)
- DeviceNet
- DNP 3.0 Suite - Serial + Ethernet
- Enron Modbus Serial
- Fisher ROC/ROC+, Serial + Ethernet
- Fuji Flex PLCs
- GE SRTP or EGD Ethernet & Focas1 Ethernet
- GE CCM, SNP & SNP-X Serial
- Honeywell UDC 3000/3300 & HC900
- Idec
- IEC61850 MMS Client
- Intelligent Actuator Super
- SEL-OPC Client Suite (accesses OPC DA, OPC UA and OPC XML-DA Servers)
- IoTech PointScan 100
- Krauss Maffei Ethernet (injection molding machines)
- Lufkin Modbus
- Mettler Toledo Scale serial
- Mitsubishi Suite: FX Programming Port & FX-Net, A/Q/QnA Series (Serial & Ethernet)
- Modbus Suite: Serial RTU & ASCII Master, Serial RTU Slave, Modbus Plus, TCP Ethernet Master/Slave & Bridging
- MT Connect client
- ODBC client driver (converts database data to OPC)
- Omni Flow Computer
- Omron Suite: Hostlink & FINS Serial, FINS Ethernet & Gateway, Temp. Controllers
- Optimization OptiLogic
- Opto 22

Function (continued)

- Partlow ASCII
- Philips PC8/PC20
- PROFIBUS
- Red Prairie logistics transactions
- Sattbus & Sattbus Ethernet
- Scanivalve Ethernet
- Siemens S5 AS-511 & 3964R
- SIMATIC/TI 5x5 Ethernet or Serial
- SIMATIC/TI TIWAY Serial
- Sixnet Ethernet I/O
- SNMP Suite (SNMP & ping data to OPC)
- SquareD Serial
- System Monitor (converts any Windows performance counters to OPC)
- Telemecanique Unitelway
- Thermowestronics Data Acq. Systems
- Torque Tool Ethernet Driver
- Toyopuc PC2 Serial & PC2/PC3 Ethernet
- Toshiba Serial & Ethernet
- Triconex TSAA Ethernet
- Wago 750 Ethernet
- Weatherford 8500 Serial
- WITS Level 0 suite (Active/Passive)
- Wonderware InTouch Client driver
- Yaskawa Memobus, MP Serial+Ethernet
- Yokogawa Suite: DX100/200, DXP & Darwin-Serial+Ethernet, YS100 Serial, HR2400 Serial, MW100 & MX100 Ethernet, CX Ethernet
- Yokogawa Green Series
- Wonderware InTouch Client driver

More information

A complete list of order data and prices, along with details of how the free test software may be obtained, can be found on the Internet under:

<http://www.softwaretoolbox.com/siemenspremium>

Or contact Software Toolbox by telephone or e-mail:

Software Toolbox Inc.
148 East Charles Street Suite A
Matthews, North Carolina, 28105
USA

Phone: +1 704 849 2773

Fax: +1 704 849 6388

E-mail: siemenspremium@softwaretoolbox.com

Premium Add-ons for SIMATIC WinCC Connectivity

TOP Server UCON

Overview

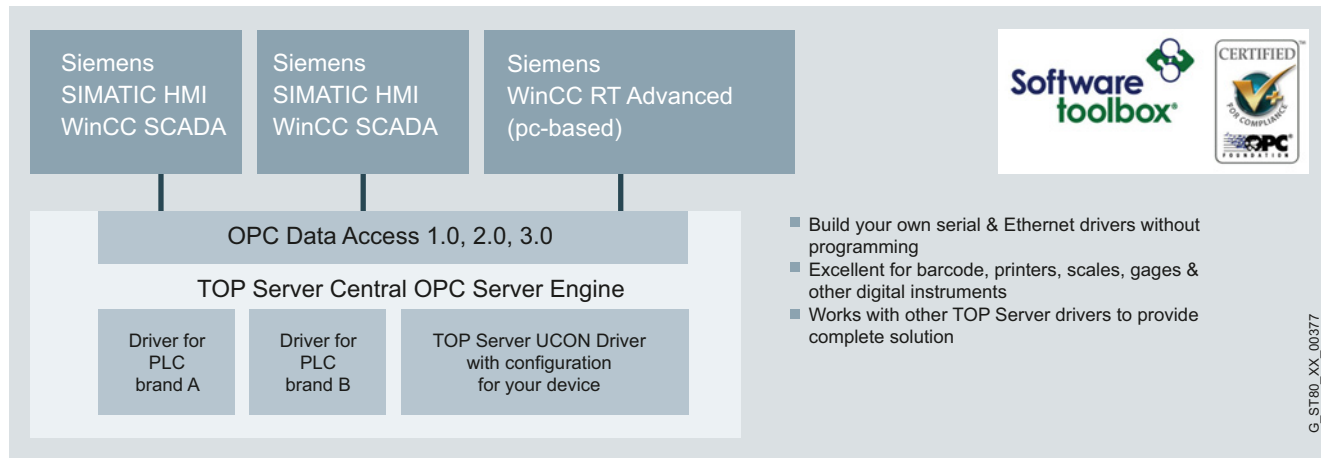

TOP Server UCON

TOP Server UCON: With point & click, you can create your own WinCC drivers for serial and Ethernet field devices

Although WinCC already offers a wide range of drivers, there are thousands of serial and Ethernet field devices for which no ready-to-use drivers for integration with SIMATIC HMI software are provided.

In such situations, you yourself could program a driver, which would quickly cost a few thousand euros. However, the TOP Server UCON OPC server represents a proven alternative for this, which can be used to create your own suitable drivers without any programming and at a fraction of the cost.

Benefits

- Expanded coupling options of WinCC with field devices
- Reduced engineering and integration cost
- Additional benefits when using WinCC as HMI/SCADA

UCON provides point-click configurations for the following devices:

- Barcode scanners and printers
- Micrometers
- Scales
- Controllers

- Laboratory devices
- Recorders
- Sensors
- Analyzers
- Special devices
- Serial RS232/422/485 devices
- TCP/IP or UDP Ethernet devices

Function

- OPC compatibility tested in conjunction with WinCC, WinCC (TIA Portal), Runtime Advanced/Professional
- OPC conformity tested for OPC DA 2.05a & 3.0 and OPC UA
- Point&Click, menu-driven configuration – no programming required
- Free online training videos
- A user-friendly Transaction Editor guides the project engineer through the read/write interface of the field device and aids in the selection and assignment of data to the OPC tags
- Sample logs are provided

- Supports solicited and unsolicited messages
- Works with modems and encapsulated Ethernet devices
- Diagnosis of raw data flow to and from the data source
- Multi-threading
- More than 256 simultaneous serial or Ethernet connections
- Adjustable timeouts and write optimizations
- Supports Windows XP, Vista, Windows 7, Windows 8, Server 2008, 2008 R2 and Server 2012, as well as Hyper-V and VMware virtualization

More information

Software Toolbox Inc.
148 East Charles Street Suite A
Matthews, North Carolina, 28105
USA

Phone: +1 704 849 2773
Fax: +1 704 849 6388

E-mail: siemenspremium@softwaretoolbox.com

For more information and free TOP Server UCON test software version in internet:

<http://www.softwaretoolbox.com/siemenspremium>

Overview

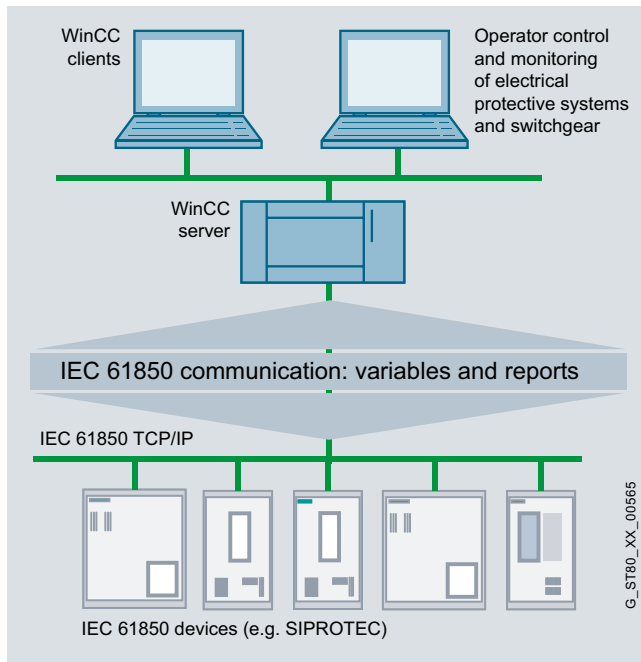

IEC 61850 communication channel

IEC 61850 is the globally valid standard for communication in electrical protective systems and medium-voltage switchgear.

All leading manufacturers have therefore already implemented IEC 61850 in their control and protective equipment. The open standard means simpler configuration, compatibility with future expansions, lower maintenance costs, and thus lower life cycle costs.

The communication channel makes it possible to operate and monitor IEC 61850-enabled devices with WinCC. This means the automation of a production plant can be expanded by the addition of support for IEC 61850 devices for the electrical system.

Benefits

- Simple integration of high-voltage and medium-voltage level electrical devices into the SIMATIC HMI world
- A SIMATIC system for production plants and electrical systems
- Security of investment thanks to globally valid IEC 61850 standard
- Powerful communication
- Simple configuration and expandability

Function

Configuration

The wizard included in the scope of delivery is used to configure data communication via IEC 61850 with an IED (intelligent electric device). It provides the option of importing the .icd configuration file of the device. Alternatively, the wizard can also access the device online and upload the current configuration. The tags and alarms selected by the user are then transferred to the WinCC data management system.

Communication

The IEC 61850 communication channel is an IEC 61850 MMS client. It establishes a connection to each of the configured IEC 61850 MMS server devices. This enables read/write data communication with the devices. Buffered reports continue to be supported: Status changes reported by the device are inserted with time stamp in the WinCC alarm logging system.

Diagnostics

The accompanying values for measured values of the control and protective equipment, such as quality codes, are transferred in the same way as diagnostics information on the connection status of each device. This ensures detailed communication diagnostics are available.

Functionality

The communication channel enables data exchange with IEC 61850 devices. The station controller or the SICAM PAS solution package is available for automation tasks or for connecting devices and control centers.

Ordering data

Article No.

WinCC channel

WinCC channel IEC 61850 MMS client

License for one server, WinCC V7.0 or higher, for communication with

- Up to 20 IEC61850 devices, USB dongle
- Up to 50 IEC61850 devices, USB dongle
- Up to 256 IEC61850 devices, USB dongle

9AE4110-7AA00

9AE4110-7AB00

9AE4110-7AC00

More information

Siemens AG
Digital Factory Division
Customer Services DF&PD
Plant Data Services
Karlsruhe

Tel.: +49 721 595-6380

Fax: +49 721 595-6383

Email: function.blocks.industry@siemens.com

Premium Add-ons for SIMATIC WinCC Process Management

PM-CONTROL system software

Overview

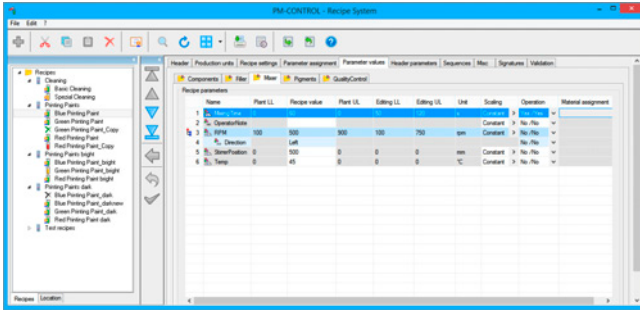

PM-CONTROL system software

Production rules, recipes or parameter data records are required as specifications for production in a wide variety of industries; they must be managed in a high-performance database, monitored for changes and clearly presented. These specifications result in production jobs which are used to plan the production sequence.

PM-CONTROL presents the user with a flexible parameter control tool, with a user interface that can be seamlessly integrated into the WinCC user interface.

Parameters of different types are saved in data records as recipes. The logging of recipe changes in an audit trail, the support of single or duplicate electronic signatures and the automatic versioning of recipe data records make PM-CONTROL an ideal tool in the regulated industry.

PM-CONTROL is suitable for complex tasks with automatic scaling of quantities, dynamic calculation of recipe values combined with convenient job scheduling and including automatic transfer of scheduled jobs to the production units.

Enhancements such as the graphic planning board for job display, the rule-based check of recipe parameters as well as the option of creating a completely separate recipe editor continue the trend toward more ease of use, greater transparency and greater flexibility. The openness of PM-CONTROL enables problem-free connection to higher-level host systems (e.g. MRP systems) at the plant and production management level.

Customized for simple use cases with manual retrieval of recipes from the recipe database, PM-CONTROL is offered in a compact version.

Function

Integral "wizards" for setting up recipe data records and signing of production jobs, for example, provide the user with the best possible support for operator control and reduce training time to an absolute minimum.

Configuration:

The production units for processing the orders are created in the Topology Manager with all the necessary parameters and the tag connections configured.

The settings for selecting the operating mode are determined by the input options in the job wizard:

- Jobs with / without target quantity
- Consideration of min. / max. limit values
- Scheduled quantity for job distributed between multiple batches
- Individual parameter set or recipes comprise several steps

The defined authorizations and requirements for signatures have an effect on the operation of the recipe system and job control during runtime.

The integrated, central PM-LIBRARY engineering library facilitates the exchange and re-use of finished configurations.

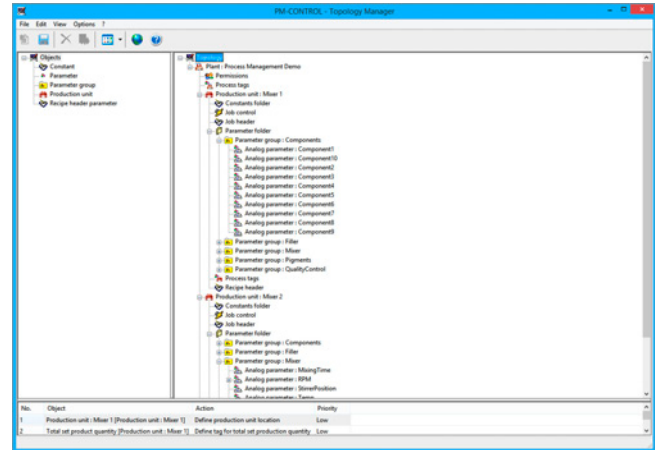

PM-CONTROL Topology

Recipe system:

The recipe data records are created based on the previously defined parameters. The recipe values are kept absolute for simple applications.

In connection with PM-CONTROL job control, the recipe values can be scaled in linear fashion depending on the quantity, or they can be calculated according to a formula or depending on other recipe values, job values or current measured values. Configurable validation rules check the consistency of the recipe data. Freely definable sequence criteria point to impermissible production sequences in job planning.

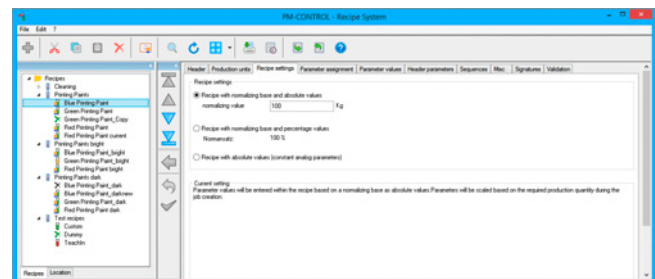

PM-CONTROL Recipe system

Function (continued)

Job display:

The job display provides an overview for each production unit regarding planned, current and completed jobs. New job creation is either based on a recipe or a production unit or generated from a template. A job comprises one or more batches or recipe steps.

The job data can be loaded automatically upon request by the production unit, with specification of a start time, or manually. Setpoints can be transferred to WinCC, PCS7 as well as over OPC DA or OPC UA even if a job includes setpoints for more of these destinations in combination.

Recipe/job values can be modified not only for planned jobs but also for currently loaded jobs with the corresponding approval. If jobs are signed electronically, the signature is requested once again following any modification. The system's own audit trail records the change history with time stamp, logged-on user(s), parameter name, as well as old and new values for each batch or recipe step, making the process transparent and traceable.

The setting of a retention period governs the deletion of processed jobs.

No.	Status	Job name	Recipe name	Recipe number	Set quant.	Batch no.	Customer	Begin	Planned duration
-11	✓	A54	Green Printing Paint	GPP-1	300	3 of 3		2015-12-02 10:32:56	0000:15
-10	✓	A56	Red Printing Paint	GPP-1	500	3 of 5		2015-12-02 10:53:48	0000:25
-9	✓	A57	Green Printing Paint	GPP-1	400	4 of 4		2015-12-10 10:18:05	0000:20
-8	✓	A58	Green Printing Paint	GPP-1	2000	20 of 20		2016-01-13 13:01:09	0001:40
-7	✓	A59	Green Printing Paint	GPP-1	399	4 of 4		2016-01-27 16:08:15	0000:20
-6	✓	A60	Green Printing Paint	GPP-1	300	3 of 3		2016-02-02 14:07:16	0000:15
-5	✓	A61	Green Printing Paint	GPP-1	100	1 of 1		2016-02-09 14:24:11	0000:05
-4	✓	A55	Blue Printing Paint	GPP-1	300	3 of 3		2016-02-16 09:32:15	0000:15
-3	✓	A55	Blue Printing Paint	GPP-1	300	3 of 3		2016-03-03 11:16:48	0000:15
-2	✓	A58	Red Printing Paint	GPP-1	500	3 of 5		2016-03-03 11:43:26	0000:25
-1	✓	A60	Green Printing Paint	GPP-1	300	3 of 3		2016-03-04 13:35:06	0000:15

No.	Status	Job name	Recipe name	Recipe number	Set quant.	Batch no.	Customer	Begin	Planned duration
1	✓	A62	Blue Printing Paint	GPP-1	200	1 of 2	Meat	2016-04-12 13:26:39	0000:10

No.	Status	Job name	Recipe name	Recipe number	Set quant.	Batch no.	Customer	Begin	Planned duration
1	✓	A63	Green Printing Paint	GPP-1	300	0 of 3	Soft	2016-04-12 13:36:40	0000:15
2	✓	A60a	Green Printing Paint	GPP-1	300	0 of 3	Siemens	2016-04-12 13:31:40	0000:15
3	✓	A66	Blue Printing Paint	GPP-1	200	0 of 2	Moore	2016-04-12 14:06:40	0000:10
4	✓	A65	Blue Printing Paint	GPP-1	400	0 of 4	Walt	2016-04-12 14:16:48	0000:20

PM-CONTROL Job view

Planning board:

The planning board display is a graphical representation of the estimated runtime for planned jobs. The time period under consideration can be adjusted as needed from the surrounding process picture so that the time period relevant for planning is always shown, for example, one day, one week, one month or only the next hour.

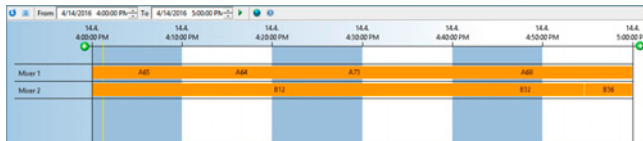

PM-Control Planning board

Ordering data

Article No.

PM-CONTROL system software Type S, Compact version

Single-user/multi-user system server that runs on an interconnected WinCC system and comprises a topology manager, recipe system, and ActiveX Control for recipe pre-selection (multiple independent production units)

9AE7110-2SS10-1AA0

PM-CONTROL system software Type S, Standard version

Single-user/multi-user system server that runs on an interconnected WinCC system and comprises a topology manager, recipe system, and job control (single production unit)

9AE7110-2SS20-1AA0

PM-CONTROL system software Type S, Professional version

Single-user/multi-user system server that runs on an interconnected WinCC system and comprises a topology manager, recipe system, and job control (multiple independent or linked production units)

9AE7110-2SS30-1AA0

PM-CONTROL system software, Type C

Multi-user system client that runs with system package Type S (Compact, Standard, Professional) on an interconnected WinCC system or as thin client (without WinCC) consisting of a recipe system and job control

9AE7110-4SC03-1AA0

Note:

Additional PM-CONTROL configurations available on request.

More information

Siemens AG
Industrial Solutions and Services
WinCC Competence Center Mannheim

Phone: +49 (0)621 456-3269
Fax: +49 (0)621 456-3334

Email: WinCCAddon.automation@siemens.com

Additional information is available on the Internet at:

<http://www.siemens.com/process-management>

Premium Add-ons for SIMATIC WinCC Process Management

PM-QUALITY system software

Overview

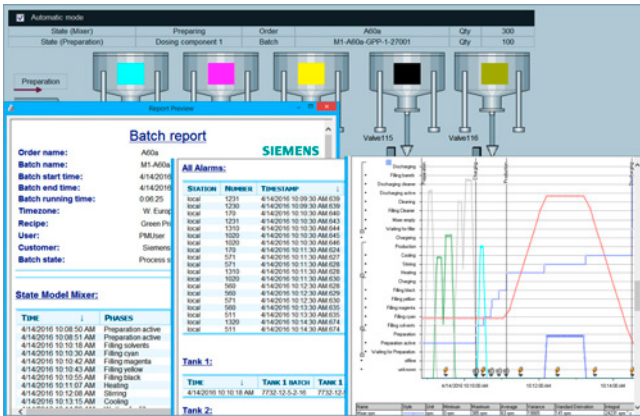

PM-QUALITY system software

The mandatory quality certification in form of a manufacturing protocol required for all industries regulated by the FDA has become a standard requirement in almost all industries.

Core functions of a comprehensive quality management system, such as the complete recording, processing and archiving of batch-related data such as trends, messages, production set-points and actual production values, audit trails and laboratory values are the strengths of PM-QUALITY. This allows data from WinCC, PCS7, WinCC (TIA) RT Professional and Advanced or via text import, OPC/DA and OPC/UA from a variety of sources to be combined, merged into meaningful reports, and stored in long-term archives.

PM-QUALITY ensures the required transparency, both when seamlessly integrated into the WinCC, PCS7 or WinCC RT Professional and Advanced (TIA Portal) user interface and as a separate application.

The processing of measured values with the aid of graphical calculation rules, the integration of day, week and shift logs with an integrated shift calendar, and the creation of reports in Microsoft Excel are consistent expansions of the proven functionality of PM-QUALITY.

Function

Configuration:

The production units with all data that has to be collected for reporting is configured in a topology Manager. This includes process value archives for continuous collection of process values, snapshot trigger for event-driven collection of process values, and alarm logs for alarms and audit trail entries.

The production process can be structured with the help of phases and status models. The individual phases or status are archived with a time stamp. For complex processes covering multiple production units, the production units can be linked to a plant unit. Reports include data for production units or entire plant section.

The integrated, central PM-LIBRARY engineering library facilitates the exchange and re-use of finished configurations.

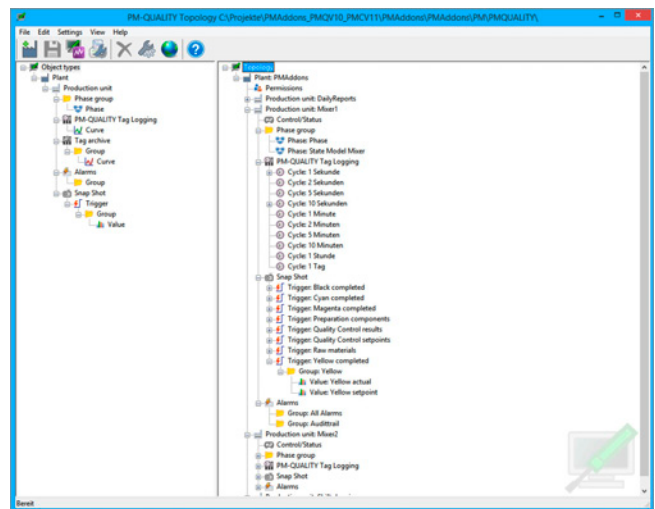

PM-QUALITY topologie manager

Data acquisition:

Data acquisition is initiated either when the batch starts or at pre-defined times, for example, at the beginning of a shift, and ended once the batch or shift is complete. A unique batch number is generated under which the data can be archived in the PM-QUALITY database.

Data archiving:

Completed and released batches can be automatically exported for long-term archiving. Placeholders integrated in the export path ensure clearly structured data storage. The Data View application or the PM-QUALITY Client is used to display the exported data.

Function (continued)

Trend display in the process picture:

The display of trends in which multiple batch sequences can be compared becomes a comprehensive analysis tool with maximum operating convenience thanks to the simultaneous display of alarms, triggered recordings of measured values, phase lines, status models and comments. The integrated zoom function, axes relocation and the display of specific time periods allow individual measuring points to be precisely evaluated. Detailed information for each event is output in a tooltip. Comments can be added later in time-based trends.

The extremely flexible configuration of the trend diagrams also offers the configuration of trends in the form f(x). Saved in templates, the various configurations can be retrieved at any time. The ActiveX control is integrated into a process picture.

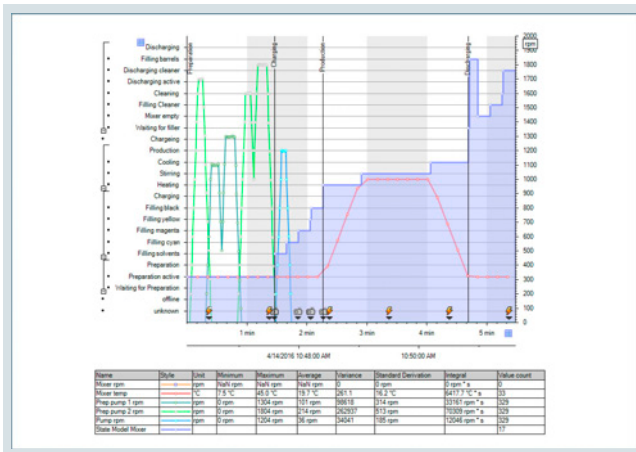

PM-QUALITY trend curve control

Creating reports:

With the integrated Report Layout Editor, different views of the batch archives can be conveniently implemented, compliant with existing design guidelines.

Multiple protocol blocks that can be easily dragged into the protocol for configuration are available for the design.

An integrated preview shows the data of a selected batch based on the configured report at any time. In addition to the protocol blocks offered by default, data evaluation can be inserted into the protocol with VB script. Various style sheets are already included in the scope of delivery and you can add your own without any problems.

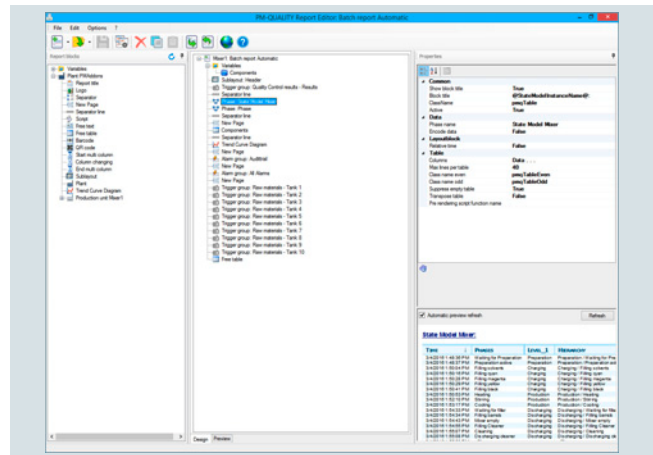

PM-QUALITY report editor

Batch table in the process picture:

Batches can be found at any time thanks to individually configurable filters. The batch data can be displayed on a screen based on the selected protocol, it can be printed or exported in the HTML or XML formats or in the database format. The ActiveX control is integrated into a process picture.

Name	Start time	End time	Duration	Batch status	Recipe	User	Reference No.	Accompanying
MF-A03-GPP-1-001	1/15/2016 12:01:09	1/15/2016 12:07:44	00:06:35	Released	Green Protein	PKA001		
MF-A03-GPP-1-002	1/15/2016 12:07:54	1/15/2016 12:14:21	00:06:27	Released	Green Protein	PKA001		
MF-A03-GPP-1-003	1/15/2016 12:14:31	1/15/2016 12:21:08	00:06:36	Released	Green Protein	PKA001		
MF-A03-GPP-1-004	1/15/2016 12:21:18	1/15/2016 12:27:55	00:06:36	Released	Green Protein	PKA001		
MF-A03-GPP-1-005	1/15/2016 12:28:07	1/15/2016 12:34:44	00:06:36	Released	Green Protein	PKA001		
MF-A03-GPP-1-006	1/15/2016 12:34:53	1/15/2016 12:41:30	00:06:36	Released	Green Protein	PKA001		
MF-A03-GPP-1-007	1/15/2016 12:41:39	1/15/2016 12:48:16	00:06:37	Released	Green Protein	PKA001		
MF-A03-GPP-1-008	1/15/2016 12:48:25	1/15/2016 12:55:02	00:06:37	Released	Green Protein	PKA001		
MF-A03-GPP-1-009	1/15/2016 12:55:11	1/15/2016 1:01:48	00:06:36	Released	Green Protein	PKA001		
MF-A03-GPP-1-010	1/15/2016 1:01:57	1/15/2016 1:08:34	00:06:36	Released	Green Protein	PKA001		
MF-A03-GPP-1-011	1/15/2016 1:08:43	1/15/2016 1:15:20	00:06:37	Released	Green Protein	PKA001		
MF-A03-GPP-1-012	1/15/2016 1:15:29	1/15/2016 1:22:06	00:06:36	Released	Green Protein	PKA001		
MF-A03-GPP-1-013	1/15/2016 1:22:15	1/15/2016 1:28:52	00:06:36	Released	Green Protein	PKA001		
MF-A03-GPP-1-014	1/15/2016 1:29:01	1/15/2016 1:35:38	00:06:36	Released	Green Protein	PKA001		
MF-A03-GPP-1-015	1/15/2016 1:35:47	1/15/2016 1:42:24	00:06:36	Released	Green Protein	PKA001		
MF-A03-GPP-1-016	1/15/2016 1:42:33	1/15/2016 1:49:10	00:06:36	Released	Green Protein	PKA001		
MF-A03-GPP-1-017	1/15/2016 1:49:19	1/15/2016 1:55:56	00:06:36	Released	Green Protein	PKA001		
MF-A03-GPP-1-018	1/15/2016 1:56:05	1/15/2016 2:02:42	00:06:36	Released	Green Protein	PKA001		
MF-A03-GPP-1-019	1/15/2016 2:02:51	1/15/2016 2:09:28	00:06:36	Released	Green Protein	PKA001		
MF-A03-GPP-1-020	1/15/2016 2:09:37	1/15/2016 2:16:14	00:06:36	Released	Green Protein	PKA001		
MF-A03-GPP-1-021	1/15/2016 2:16:23	1/15/2016 2:23:00	00:06:36	Released	Green Protein	PKA001		
MF-A03-GPP-1-022	3/5/2016 11:48:54	3/5/2016 11:56:14	00:06:19	Process status	Red Protein	PKA001		
MF-A03-GPP-1-023	3/5/2016 11:56:23	3/5/2016 12:03:42	00:06:19	Process status	Red Protein	PKA001		
MF-A03-GPP-1-024	3/5/2016 12:03:51	3/5/2016 12:11:10	00:06:19	Process status	Red Protein	PKA001		
MF-A03-GPP-1-025	3/5/2016 12:11:19	3/5/2016 12:18:38	00:06:19	Process status	Red Protein	PKA001		
MF-A03-GPP-1-001	1/27/2016 4:38:18	1/27/2016 4:16:58	00:21:14	Released	Green Protein	PKA001		
MF-A03-GPP-1-002	1/27/2016 4:17:08	1/27/2016 4:25:18	00:08:10	Released	Green Protein	PKA001		
MF-A03-GPP-1-003	1/27/2016 4:25:28	1/27/2016 4:33:38	00:08:09	Released	Green Protein	PKA001		
MF-A03-GPP-1-004	1/27/2016 4:33:48	1/27/2016 4:41:58	00:08:09	Released	Green Protein	PKA001		
MF-A03-GPP-1-001	3/6/2015 2:34:50 PM	3/6/2015 2:40:44 PM	00:05:54	Released	Green Protein	PKA001		
MF-A03-GPP-1-002	3/6/2015 2:40:53 PM	3/6/2015 2:46:47 PM	00:05:52	Released	Green Protein	PKA001		
MF-A03-GPP-1-003	3/6/2015 2:46:56 PM	3/6/2015 2:52:50 PM	00:05:52	Released	Green Protein	PKA001		
MF-A03-GPP-1-001	3/2/2016 2:07:18 PM	3/2/2016 2:13:12 PM	00:05:54	Process status	Green Protein	PKA001		

PM-QUALITY batch table

Redundancy option:

The Data Center option provides PM-QUALITY with a redundancy function. The batch data is acquired on two separate computers by one PM-QUALITY server each. Once the batch is complete, the Data Center compares the data recorded by the two PM-QUALITY servers and exports the result to an export database.

Premium Add-ons for SIMATIC WinCC

Process Management

PM-QUALITY system software

Ordering data

PM-QUALITY system software Type S, "Standard" version Single-user/multi-user system server that runs on an interconnected WinCC system for one production unit	9AE7111-2SS20-1AA0
PM-QUALITY System software type S version "Professional" Without data center Single-user/multi-user system server that runs on an interconnected WinCC system for multiple autonomous and interlinked production units.	9AE7111-2SS30-1AA0
PM-QUALITY System software type S version "Professional" Without data center For data redundancy synchronization. The system package is to be installed on both redundant computers.	9AE7111-2SS30-1AB0
PM-QUALITY system software Type C Multi-user system client that runs with the Type S system package on an interconnected WinCC system or as thin client (without WinCC)	9AE7111-4SC01-1AA0

Note:

Additional PM-QUALITY configurations available on request.

More information

Siemens AG
 Industrial Solutions and Services
 WinCC Competence Center Mannheim

Phone: +49 (0)621 456-3269

Fax: +49 (0)621 456-3334

Email: WinCCAddon.automation@siemens.com

Additional information is available on the Internet at:

<http://www.siemens.com/process-management>

Overview

ACRON on the basis of WinCC covers all requirements of historical data processing in the water/wastewater area, from the smallest applications right up to large distributed system architectures.

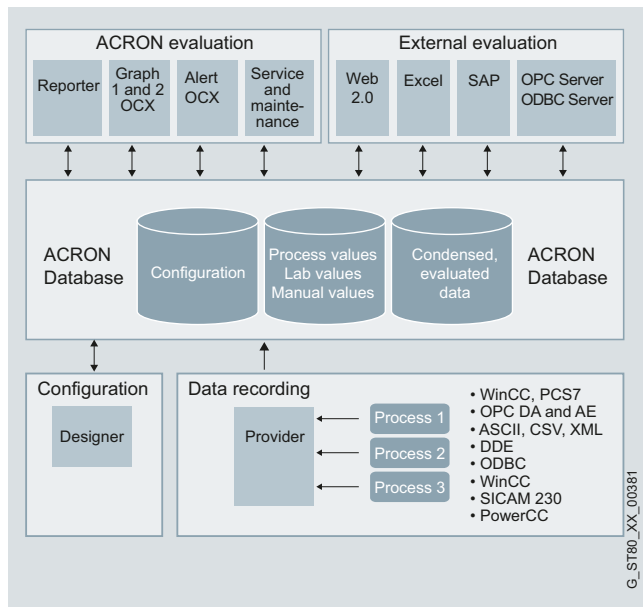

The following ACRON modules are available:

- **Provider**
Supports data acquisition from any sources
- **Reporter**
The convenient user interface of ACRON
- **Graph**
Characterized by convenient and user-friendly representation in trend curves
- **AC Job**
Management module for all automatic printout and e-mail distribution of reports
- **Error and maintenance module**
ACRON tool for creating all the necessary error and alarm reports and generating their comprehensive statistics
- **PDCA module** (Plan DO Check_Act)
- Energy data management in accordance with ISO 50001
- Excel Add-In
Convenient access to all data in ACRON for simple and fast reading in of values

Benefits

ACRON on the basis of WinCC has a rugged and fault-tolerant client-server architecture. The software is scalable and can keep pace with requirements.

ACRON for WinCC is also characterized by ease of use, flexibility and simple configuring.

Other features include:

- High performance and extremely fast response times
- Time-oriented and/or change-oriented recording
- Time resolution in the millisecond range
- Redundant database
- Multiserver concept for distributed architectures
- Arithmetic operations with more than 100 000 data points
- Integrated unit system, formula module with prepared calculation algorithms
- Maximum security in data acquisition (three-level cache)
- Manual or automatic data backup to different data carriers/media
- Detailed breakdown for user administration
- Low memory requirements
- All reports possible (including batch or shift-related)
- Quick configuration
- Client-capable web portal with graphs and reports (web only, not a plug-in)
- Languages with switchover function: English, German and other languages possible on request
- Executable in Windows 2008/2012 Server, Windows 7 (64-bit), Windows 8.x, Windows 10 as of version ACRON 8.3 and higher, connection also possible to older operating systems
- ISO 50001 TÜV-certified, M260, M207, 216A, GMP, 21cfr11, BlmSchV, TA air, NWBA, etc.

Premium Add-ons for SIMATIC WinCC

Industry and technology solutions

ACRON 8 for WinCC

Function

Reporting

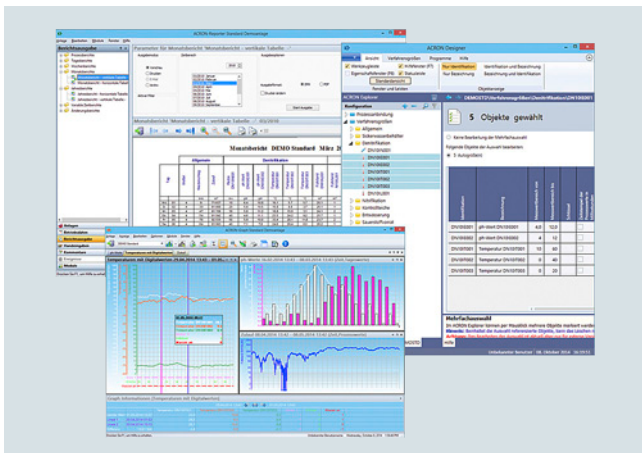

ACRON for WinCC, reports

ACRON for WinCC creates informative reports from the process data over freely selectable time ranges. Useful compression algorithms generate data for daily, weekly, monthly, and annual reports, as well as freely selectable time periods.

Event or batch reports are determined by start and end conditions. There are also reports and application examples available from different sectors. The report wizard supports fast generation even of complex reports, and reduces the configuring time.

More information

Videc GmbH
Mr. Dieter Barelmann
Contrescarpe 1

28203 Bremen, Germany

Phone: +49 (0)421 339050-0

Fax: +49 (0)421 3379561

E-mail: info@videc.de

Additional information is available on the Internet at:

<http://www.acron8.de>

or

<http://www.acron8.com>

Overview

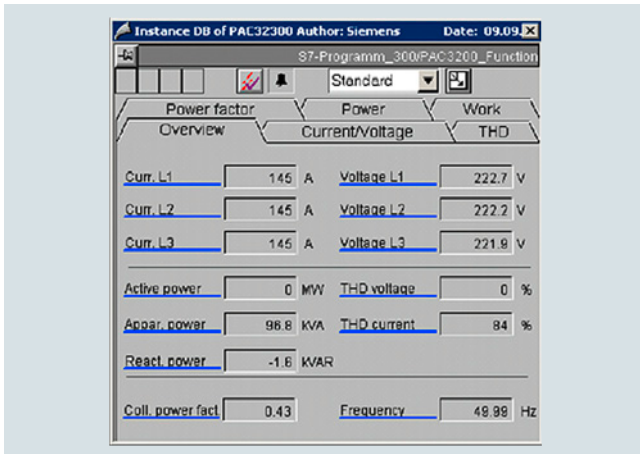

Block library PAC3200 for SIMATIC WinCC

The 7KM PAC3200 library for SIMATIC WinCC is a block library for the 7KM PAC3200 and 7KM PAC4200 measuring instruments. It permits the seamless integration of measuring instruments in WinCC.

The 7KM PAC3200 library for SIMATIC WinCC comprises a driver block, a diagnostics block, and the faceplates. Blocks in the SIMATIC S7 supply the faceplates on the user interface of WinCC with energy data, generate messages, and ensure connection to the WinCC alarm logging.

Faceplates

The faceplates serve as a user interface for operator control and monitoring and permit the display and operation of technologically important values and functions of the 7KM PAC3200/4200 measuring instrument in WinCC.

There are bi-directional communication connections on the system side between the faceplates and the blocks, as well as between the blocks and the 7KM PAC3200/4200 measuring instruments. They support the display of values in the faceplates and the forwarding of entries to the device.

This makes the 7KM PAC3200/4200 measuring instruments an integral part of WinCC.

System requirements

The 7KM PAC3200 library for SIMATIC WinCC is released for WinCC V7.0, V7.1, V7.2, V7.3.

The AS-OS Engineering and Basic Process Control WinCC options must be installed. The block library is available for S7-300, S7-400, and WinAC RTX.

At least one S7 CPU317-2DP is required for implementation with S7-300. At least one S7 CPU414-2 is required for implementation with S7-400.

The same operating systems as for SIMATIC WinCC are supported. Use of the PAC expansion module PROFIBUS DPV1 V (7KM9300-0AB00-0AA0).

Benefits

- Total integration of the 7KM PAC3200/4200 measuring instruments in SIMATIC WinCC over PROFIBUS DPV1. The library is a certified WinCC option.
- Read-out and display of device data
- Input of limits for monitoring by the driver block
- Resetting of values on the device (min./max. values)

Application

The 7KM PAC3200 library for SIMATIC WinCC is used in all industries where WinCC is used. Pre-defined blocks and symbols assure the user that only tested and certified product components are being used.

In addition to the cyclic connection, there is also an acyclic connection for pure visualization tasks. With the acyclic connection, the process image of the SIMATIC CPUs can be used more efficiently.

Ordering data

Article No.

7KM PAC3200 library for SIMATIC WinCC¹⁾

- Engineering license
 - For operation on a WinCC OS (single-user workstation or server) and an automation system (AS)
 - When additional WinCC OS are used, an engineering license is required for each WinCC OS
- Runtime license
 - For operation on an additional automation system (AS)

3ZS2791-1CC11-0YG0

3ZS2791-1CC10-6YH0

PAC/3WL/3VA SIMATIC PCS7 SW+COL library¹⁾

- Engineering license
 - The PAC/3WL/3VA for SIMATIC PCS 7 V2.0 library with an engineering and AS runtime license for PCS 7 V8.0 SP2, V8.1, V8.1 SP1
 - When additional PCS 7 OS are used, an engineering license is required for each PCS 7 OS
- Runtime license
 - For operation on an additional automation system (AS)

3ZS2787-1CC30-0YG0

3ZS2787-1CC30-6YH0

¹⁾ Can also be used for 7KM PAC4200

You can find the currently supported SIMATIC WinCC versions on the Internet at:

<http://support.automation.siemens.com>

Premium Add-ons for SIMATIC WinCC

Industry and technology solutions

Sm@rtLib function library

Overview

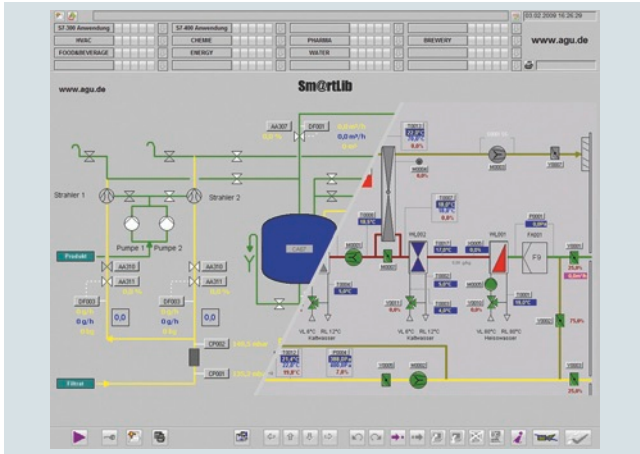

The Sm@rtLib function library is a cross-sector library that is used, among other things, for configuring automation and process control systems in the HVAC, process industry, pharmaceuticals and energy sectors.

Sm@rtLib was developed for the target system WinCC in combination with S7-300 or S7-400 controllers.

The library contains all the control functions demanded in the process industry and in building management systems. Sm@rtLib supports the chronological processing of the system messages. Interventions by the operator are entered in alarm logging.

Innovations in version 5

The innovations in version 5 of the Sm@rtLib prepared the library to become independent of the platform, which means it can be integrated into the TIA Portal and other HMI systems.

- The library has been enhanced with b new functionalities, such as maintenance operation.
- To customize the configuration, users can now freely configure colors and texts.
- The supplied icons can be easily adapted by users to meet their requirements. The library contains function blocks for the S7 controllers, and the faceplates and icons for WinCC.

Benefits

Sm@rtLib impresses customers with its efficient, easy-to-learn engineering Menus guide the operator.

The clear documentation is available in SIMATIC Manager (online help) after installation of the library.

With Sm@rtLib, complex tasks can easily be configured without the need for in-depth programming knowledge. Sma@rtLib reduces the costs in the configuration and qualification phase. The integrated simulation function supports quick testing of the software without the system.

The library has been used by well-known companies for a number of years and is defined as a standard.

The comprehensive functions of Sm@rtLib give the user a broad range of implementation possibilities, including in international projects (multi-language capability).

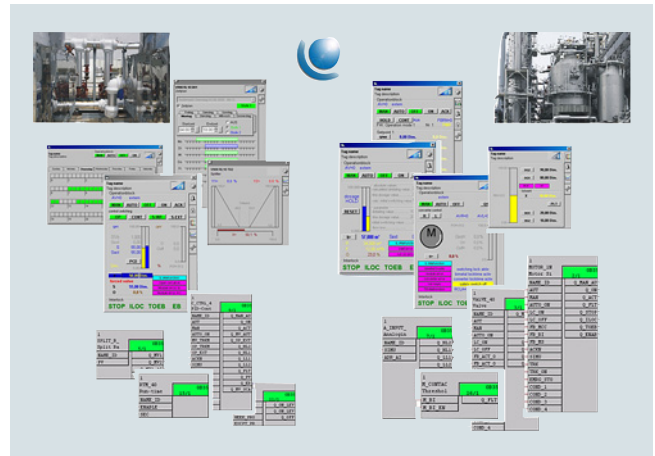

The following functions are available:

- Continuous closed-loop control, sequence control
- Split range
- Dosing unit, summing unit
- Motor 1N, Motor 2N, Motor LR
- Converter
- Valve, damper block (actuator)
- Limit contact, limit
- Analog input, analog output
- hx diagram
- Heating curve
- Week time switch
- Hour meter
- Infeed valve, mixed-air valve and exhaust valve

Licensing

Licenses are required in accordance with the number of programmable controllers. There are no limits to their use within WinCC.

Design

Design

Sm@rtLib is easy to install in the existing installation of SIMATIC Manager and WinCC.

The setup wizard guides the user through the installation process.

The library comprises technological function blocks for S7, faceplates and icons for the WinCC user interface.

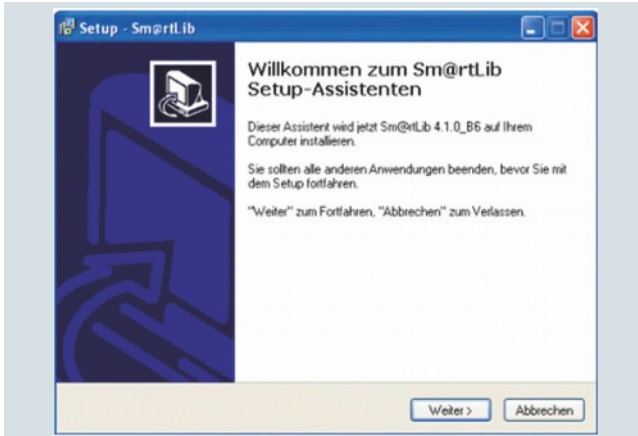

Function

The essential functions of Sm@rtLib include:

- Easy configuring in WinCC
- Suitable for WinCC with integrated operation
- Suitable for use in S7-300 and S7-400
- Operation possible as of CPU 315
- Multi-language capability (English, German, etc.)
- Control system alarm processing
- Complete user alarms with presentation of old value and new value with user name
- Suitable for use with STL, FBD, LAD or CFC
- Automatic generation of tags and messages is supported (OS compilation)
- Automatic generation of icons is supported (OS compilation)
- Open interface for connecting other operator stations (non-Siemens panels)
- Icons can be easily customized
- Clear documentation in SIMATIC Manager (online help for each function block and for engineering)

More information

AGU Planungsgesellschaft mbH
 Mr. Harry Voges

Von-Ketteler-Strasse 1
 51371 Leverkusen, Germany

Phone: +49 (0)214 8686011
 Fax: + 49 (0)214 8686019

E-mail: voges@agu.de

For more information, go to:

<http://www.agu.de>

Up-to-date information on SmartLib can be found on the Internet at:

<http://smartlib.agu.de>

Premium Add-ons for SIMATIC WinCC

Configuring tools

DCC Translation Editor

Overview

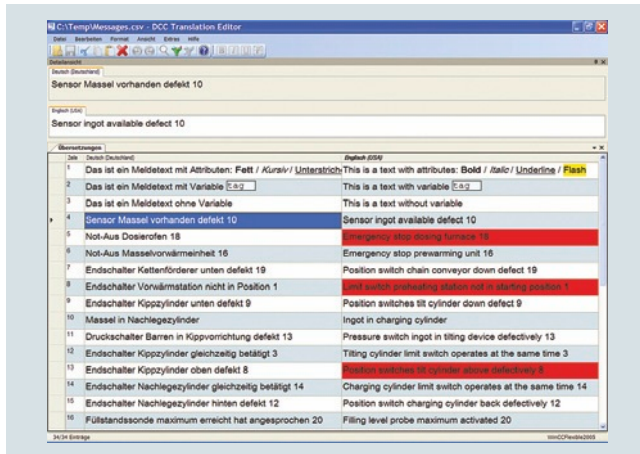

DCC Translation Editor

The DCC Translation Editor SIMATIC Edition is the only professional translation tool that is specialized in the convenient and efficient modification and maintenance of multilingual SIMATIC configurations.

With the aid of this tool, the user can handle the translations in all of the languages for WinCC (TIA Portal) just as problem-free as for all of the other standard WinCC and WinCC flexible versions.

Benefits

The advantages of the DCC Translation Editor: Increased quality and significantly reduced overhead for the multilingual capability

Safeguarding of formats

The structure and formats of the export files remain unchanged during the translation process. Headers, rows, tags and the source language are protected against deletion. The configuring engineer can then import the results of the translation into the WinCC project without problems. Thanks to automatic reading and writing of the export files at the press of a button, there is no need for error-prone conversion and time-consuming reconfiguring of computer settings.

Efficiency

The Translation Editor supports:

- Efficient translation outside the configuring thanks to full data format handling
- Simple integration into the process visualization system thanks to marking of translations that are too long
- Identification of translation errors, incorrect numbers, and missing punctuation marks (quality assurance)
- Automatic machine translation of all configuring texts

Advantage:

- Verifiable increase in quality
- Less need for adaptation in the configuration
- Less time-consuming correction loops

Flexibility

Translation Editor edits all languages without restrictions on project size.

Universal use

The translation tool has been consistently internationalized. It runs on all Microsoft operating systems, and in all languages.

Long-term security

The DCC Translation Editor supports translations for TIA and WinCC, and it is updated continuously.

Function

Innovative features

- Text length check
 - Marking of translations that are too long
- Quality assurance at the press of a button: Checking of
 - Numbers
 - Characters
 - Words
 - Consistency
 - Completeness
- Search/Replace with:
 - Wildcards
 - Regular terms
 - Any texts
- Filtering of translation texts to:
 - Empty texts
 - Non-empty texts
 - Any texts
- Automatic translation
 - Integration of Microsoft Bing & Google Translate

Standard interfaces/releases

for reading and writing to the text files (csv, xls) from:

- WinCC (5.x to 7)
- WinCC (TIA Portal)
- WinCC flexible (2005 - 2008)
- STEP 7 Basic

Available languages

- Source and target languages: All languages possible

Quality assurance

- Display of translations that are too long: Settable text length limit
- Spell check: Dictionaries for 70 languages can be linked in
- Matching filters for translations, numbers, characters, and words

Automatic translation suggestions

- Translation of empty texts or all texts with Microsoft Bing or Google Translate

Formatting, character input

- Visible text properties:
 - Bold, italic, underscored, flashing
- Tag can be moved within the field but cannot be deleted

Safety

- Deletion protection for header, lines, tags, and source language
- The source file is secured on first opening
- Automatic 10-fold backup

More information

DCC global GmbH
 Plathnerstrasse 5 A
 30175 Hannover

Phone:+49 (0)511 336 448-0

Fax:+49 (0)511 336 448-19

E-mail: info@dcc-global.com

You will find more information and a test version for downloading on the Internet at:

<https://www.dcc-global.com/TE>

Premium Add-ons for SIMATIC WinCC

Diagnostics and maintenance

ACC Alarm Control Center

Overview



Alarm Control Center

Fast and reliable alarms in the event of faults

An instant response!

In modern control systems, fast and reliable signaling of fault states to the appropriate personnel is becoming increasingly important.

The modular alarm management system "Alarm Control Center" meets these requirements with the fully automatic transmission of WinCC fault messages to a host of possible recipients:

- Android smartphones with the ACC app via SMS, internet and WLAN
- iPhones with the ACC app via internet
- Text messages to mobile phones
- Text messages to Ascom and Funktel pagers
- Voice output to telephones via ISDN and VoIP
- Text messages and voice output to HiPath/Hicom/OpenScope telephones
- Email to any recipient

Function

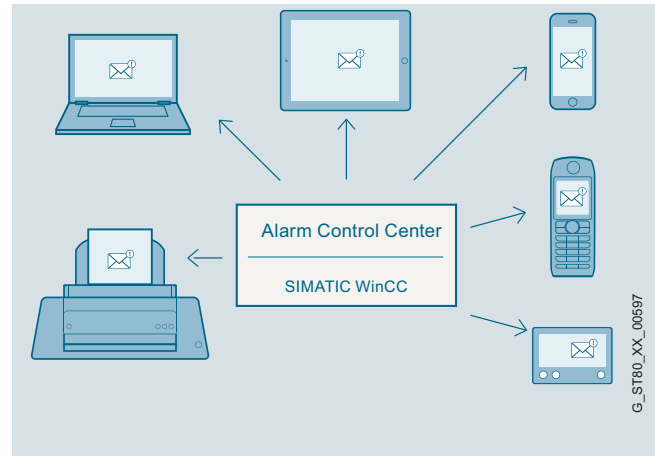

- Integrated shift and personnel management for time-dependent delivery of messages to different persons
- Extensive escalation system for reliable delivery of messages even when individual recipients cannot be reached
- Network-wide operation and configuration thanks to web capability
- Integration of operating and configuration into WCC images for control room personnel

Options

The range of available options enables individual adaptation to an operator's specific requirements, ranging from integration into a single WinCC station right through to the implementation of a company-wide fail-safe communication solution.

- Redundancy for high-availability systems
- Alarm filter for suppressing message bursts, follow-on messages, and chatter messages
- System monitoring for alerting functions by means of cyclic testing of hardware and software components
- Logging of changes to the configuration such as deletion of a call number or reorganizing the call sequence
- Dialog module for integrating customer-specific functions such as quantity querying
- Teleconferencing for up to 30 participants
- Forwarding of an emergency call to up to 10 participants
- Personnel monitoring for safeguarding personnel working alone

Ordering data

Note:

Configurations and add-ons are available on the Internet.

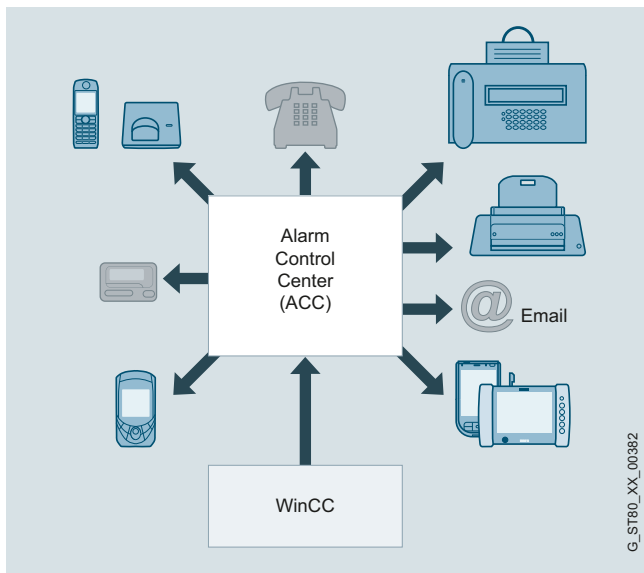

More information

Alarm IT Factory GmbH

Rotebühlstrasse 51A

D-70199 Stuttgart, Germany

Tel.: +49 (0) 711 62 007 69-0

Fax: +49 (0) 711 62 007 69-9

Email:

sales@alarmcontrolcenter.de

support@alarmcontrolcenter.de

delivery@alarmcontrolcenter.de

Additional information is available on the Internet at:

<http://www.alarmcontrolcenter.de>

Premium Add-ons for SIMATIC WinCC

Diagnostics and maintenance

PM-MAINT system software

Overview

Order	Client Name	Planned Order Number	Planned Order Name	Client Number	Client Obj.	Client Obj.	Interval	Order	Last Date	Obj.	Obj.	Next Date	Remaining	Remaining (%)
1	Task1	PLT1	PLT1	1	1	1	1	1	1	1	1	1	1	1
2	Task2	PLT2	PLT2	2	2	2	2	2	2	2	2	2	2	2
3	Value1	PLV1	PLV1	3	3	3	3	3	3	3	3	3	3	3
4	Value2	PLV2	PLV2	4	4	4	4	4	4	4	4	4	4	4
5	Value3	PLV3	PLV3	5	5	5	5	5	5	5	5	5	5	5
6	Value4	PLV4	PLV4	6	6	6	6	6	6	6	6	6	6	6
7	Value5	PLV5	PLV5	7	7	7	7	7	7	7	7	7	7	7
8	Value6	PLV6	PLV6	8	8	8	8	8	8	8	8	8	8	8
9	Value7	PLV7	PLV7	9	9	9	9	9	9	9	9	9	9	9
10	Value8	PLV8	PLV8	10	10	10	10	10	10	10	10	10	10	10
11	Value9	PLV9	PLV9	11	11	11	11	11	11	11	11	11	11	11
12	Value10	PLV10	PLV10	12	12	12	12	12	12	12	12	12	12	12
13	Value11	PLV11	PLV11	13	13	13	13	13	13	13	13	13	13	13
14	Value12	PLV12	PLV12	14	14	14	14	14	14	14	14	14	14	14
15	Value13	PLV13	PLV13	15	15	15	15	15	15	15	15	15	15	15
16	Value14	PLV14	PLV14	16	16	16	16	16	16	16	16	16	16	16
17	Value15	PLV15	PLV15	17	17	17	17	17	17	17	17	17	17	17
18	Value16	PLV16	PLV16	18	18	18	18	18	18	18	18	18	18	18
19	Value17	PLV17	PLV17	19	19	19	19	19	19	19	19	19	19	19
20	Value18	PLV18	PLV18	20	20	20	20	20	20	20	20	20	20	20
21	Value19	PLV19	PLV19	21	21	21	21	21	21	21	21	21	21	21
22	Value20	PLV20	PLV20	22	22	22	22	22	22	22	22	22	22	22

PM-MAINT system software

Efficient maintenance planning is crucial to maximize availability of the plant and to maintain it.

PM MAINT is an industry and technology-neutral maintenance management system that was designed to be used at the production level.

By providing various connection options to the existing automation landscape, PM-MAINT offers performance-based planning that is based on real machine runtimes and machining cycles in addition to purely calendar-based planning.

PM-MAINT also supports maintenance with the recording and complete documentation of unplanned repairs by means of simple, easy, workflows with a high level of user-friendliness.

Maintenance information calculated by PM-MAINT, such as recommended maintenance dates, can be shown in the existing HMI user interface for the respective units. Repair requests can easily be created directly by the machine operator.

All operator actions are recorded in a logbook and can be retraced at any time.

Function

The innovative user interface permits easy access to all maintenance-relevant information.

The convenient selection and filter options in the different views can be customized and adapted to suit your mode of operation. Views can be created for all users, individual user groups or separately for each user.

Configuration

An image of the maintenance-relevant units is created in the form of a tree structure in PM-MAINT. You can add your own object types to the available object types including properties. This means PM-MAINT perfectly adapts to your environment. Required actions, personnel, material, as well as special instructions are bundled into a unit in the planned task.

The maintenance interval can also be determined by runtime, number of switching cycles and/or a calendar interval. Evaluation is based on the current process values. The earliest calculated date is shown as the recommended maintenance date.

PM-MAINT comes with its own document management for backup of documents with maintenance-related information, such as technical data sheets, exploded views, photos, etc. The information can be assigned to the units and thus can be retrieved at any time.

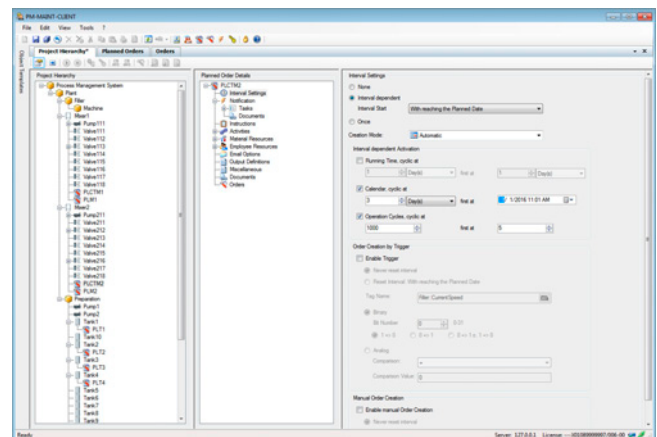

PM-MAINT, Project hierarchy

Function (continued)

Operation

The "Jobs" view shows a list of all pending maintenance jobs that were generated from the planning tasks when the recommended maintenance date was reached. For better planning of maintenance, an announcement can be created in due time prior to the job. All announcements are listed in a separate view.

he operator assigns a status to the individual jobs depending on the progress of the maintenance work (in progress, feedback provided, completed). Information on the object status, the work done, expenses for personnel and material are documented in the job feedback which can also be created multiple times for any job. Formatting rules, such as the color of the different processing statuses increase the transparency of the view.

Object	State	Type	Order Number	Order Name	Planned Date	Planned Date	Object Number	Planned Order Number	Planned Date
Head1			Order 1637	PLC702	4/13/2016 11:03 AM	4/13/2016 11:03 AM	42	PLC702	PLC702
Pump1			Order 1649	PLP1	3/16/2016 2:24 PM	3/16/2016 2:24 PM	41	PLP1	PLP1
Pump2			Order 1647	PLP2	3/15/2016 2:10 PM	3/15/2016 2:10 PM	42	PLP2	PLP2
Task1			Order 1638	PLT1	3/16/2016 2:20 PM	3/16/2016 2:20 PM	41	PLT1	PLT1
Task10			Order 1671	PLT1	3/16/2016 9:47 AM	3/16/2016 9:47 AM	41	PLT1	PLT1
Task11			Order 1688	PLT10	3/16/2016 9:46 AM	3/16/2016 9:46 AM	41	PLT10	PLT10
Task12			Order 1672	PLT2	3/16/2016 9:47 AM	3/16/2016 9:47 AM	42	PLT2	PLT2
Task3			Order 1676	PLT3	4/14/2016 1:10 PM	4/14/2016 1:10 PM	45	PLT3	PLT3
Task4			Order 1676	PLT4	4/14/2016 1:10 PM	4/14/2016 1:10 PM	46	PLT4	PLT4
Task5			Order 1685	PLT5	3/16/2016 9:46 AM	3/16/2016 9:46 AM	45	PLT5	PLT5
Task6			Order 1688	PLT6	3/16/2016 9:46 AM	3/16/2016 9:46 AM	46	PLT6	PLT6
Task7			Order 1670	PLT7	3/16/2016 9:47 AM	3/16/2016 9:47 AM	47	PLT7	PLT7
Task8			Order 1673	PLT8	3/16/2016 9:47 AM	3/16/2016 9:47 AM	48	PLT8	PLT8
Task9			Order 1688	PLT9	3/16/2016 9:46 AM	3/16/2016 9:46 AM	49	PLT9	PLT9
Value1			Order 1678	PLV11	4/14/2016 2:10 PM	4/14/2016 2:10 PM	411	PLV11	PLV11
Value2			Order 1679	PLV8	4/14/2016 2:10 PM	4/14/2016 2:10 PM	48	PLV8	PLV8

PM-MAINT, Jobs view

Repair requirements of the operators on site can be documented through seamless integration into the WinCC user interface, saved centrally and synchronized with maintenance. Information from maintenance, such as remaining operating hours until the next scheduled maintenance, can be displayed directly in WinCC.

Request Details

Request Number: New Request 62

Request Name: Value 112

Description: There is a problem

Object: Value112 (0112)

Priority: High 06

Assigned Order: Created

State: Created

Creation Date: 3/15/2016 5:16 PM

Creation: [User]

Timestamp: Action: Operator: Comment

PM-MAINT, Repair request in the HMI system

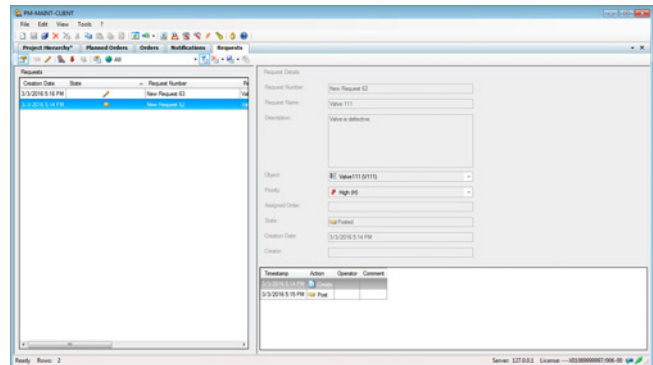

PM-MAINT, pending requirements

Transparency and ease of use

- The content of the different views shown here can be defined with convenient filter and formatting rules that are saved for individual users, user groups or globally. This means the familiar work environment is available every time you access PM-MAINT
- Navigation between linked objects (e.g. from maintenance object, to planning task, to completed maintenance jobs all the way to individual job feedback) offers access to all information in seconds due to context-dependent hyperlinks
- Operating hours and switching cycles can be integrated from WinCC, PCS7, WinCC flexible, WinCC (TIA) or via text import and OPC DA / OPC UA from additional sources for performance-based maintenance
- All lists available in PM-MAINT can be transferred directly to Microsoft Excel for easy transfer of maintenance information

Ordering data

Article No.

PM-MAINT Type S system software

9AE7104-2SS30-1AA0

Single-user/multi-user system server that runs on an interconnected WinCC system

PM-MAINT Type C system software

9AE7104-4SC00-1AA0

Multi-user system client that runs with system package Type S on an interconnected WinCC system or as a thin client (without WinCC)

Note:

Additional PM-MAINT configurations available on request.

More information

Siemens AG
Industrial Solutions and Services
WinCC Competence Center Mannheim

Phone: +49 (0)621 456-3269
Fax: +49 (0)621 456-3334

E-mail: WinCCAddOn.automation@siemens.com

Additional information is available on the Internet at:

<http://www.siemens.com/process-management>

Premium Add-ons for SIMATIC WinCC

Diagnostics and maintenance

PM-ANALYZE system software

Overview

Hardware interrupts, fault, status and operation messages from various sources contain a wealth of information which often only becomes visible by means of computer-aided analysis.

Reduced downtime and maintenance times, early detection of signs of wear and tear, localization of error sources or weak points are just a few examples. Problems in production plant are signaled by alarms which are the starting point for evaluations and analyses with PM-ANALYZE.

Period	From	To	Area	Class	Number	Alarm Count	Percentage	
31	08	14.14.2018 1:00 PM	14.14.2018 2:00 PM	Preparation	Process message	360	5	1,42 %
32	08	14.14.2018 1:00 PM	14.14.2018 2:00 PM	Preparation	Process message	361	2	0,57 %
33	08	14.14.2018 1:00 PM	14.14.2018 2:00 PM	Preparation	Process message	370	4	1,14 %
34	08	14.14.2018 1:00 PM	14.14.2018 2:00 PM	Preparation	Process message	371	5	1,42 %
35	08	14.14.2018 1:00 PM	14.14.2018 2:00 PM	Preparation	Process message	380	4	1,14 %
36	08	14.14.2018 1:00 PM	14.14.2018 2:00 PM	Preparation	Process message	380	5	1,42 %
37	08	14.14.2018 1:00 PM	14.14.2018 2:00 PM	Preparation	Process message	380	2	0,57 %
38	08	14.14.2018 1:00 PM	14.14.2018 2:00 PM	Preparation	Process message	390	5	1,42 %
39	08	14.14.2018 1:00 PM	14.14.2018 2:00 PM	Preparation	Process message	390	2	0,57 %
40	08	14.14.2018 1:00 PM	14.14.2018 2:00 PM	Preparation	Process message	390	5	1,42 %
41	08	14.14.2018 2:00 PM	14.14.2018 3:00 PM	Alarm	Alarm	1340	12	0,92 %
42	08	14.14.2018 2:00 PM	14.14.2018 3:00 PM	Alarm	Process message	1230	3	0,25 %
43	08	14.14.2018 2:00 PM	14.14.2018 3:00 PM	Alarm	Process message	1231	3	0,25 %
44	08	14.14.2018 2:00 PM	14.14.2018 3:00 PM	Alarm	Process message	1231	3	0,25 %
45	08	14.14.2018 2:00 PM	14.14.2018 3:00 PM	Alarm	Process message	1231	3	0,25 %
46	08	14.14.2018 2:00 PM	14.14.2018 3:00 PM	Alarm	Process message	1231	2	0,17 %
47	08	14.14.2018 2:00 PM	14.14.2018 3:00 PM	Alarm	Process message	1230	3	0,25 %
48	08	14.14.2018 2:00 PM	14.14.2018 3:00 PM	Alarm	Process message	1231	5	0,42 %
49	08	14.14.2018 2:00 PM	14.14.2018 3:00 PM	Alarm	Process message	1231	6	0,47 %
50	08	14.14.2018 2:00 PM	14.14.2018 3:00 PM	Alarm	Process message	1230	8	0,65 %
51	08	14.14.2018 2:00 PM	14.14.2018 3:00 PM	Alarm	Process message	1231	2	0,17 %

System software PM-ANALYZE

PM-ANALYZE not only allows the chronological display of messages from different sources, it also provides an optimal overview with its user-friendly filters and analysis options. The excellent performance during evaluation of large amounts of messages is another advantage of PM-ANALYZE.

Analysis results can be imported directly into Microsoft Excel and be further processed there.

Function

By combining and centrally archiving messages from PCS7, WinCC and WinCC (TIA) RT Professional, the event log of the Windows operating system, as well as any other sources by means of text import, PM-ANALYZE makes it possible to localize complex interrelations.

Configuration

The alarm logs in the PM-SERVER application software, which is included in the scope of delivery, are the basis for evaluation. The PM-SERVER can combine messages from different HMI systems in chronological order in its own alarm logs or can import them via text import into the alarm logs. Intelligent mapping sorts the contents of the various incoming messages.

Preparations for filtering in the PM-ANALYZE Client are made and the colors of the messages in the display area are configured in the PM-ANALYZE topology manager.

Filter	State	Color	Block
AreaClass	1	Area	
AreaClass	1	Area	
AreaClass	1	Area	
SourceAndDate	1	Source	
SourceAndDate	2	Date	
StatusAndSource	1	Status	
StatusAndSource	2	Source	

PM-ANALYZE Topology

Message display

All current messages in a selected alarm log can, for example, be displayed in a control center for monitoring. This display is updated automatically.

ID	Date	Area	Class	Status	Source
1230	14.14.2018 2:00:00 PM	Area	Class	OK	Source
1231	14.14.2018 2:00:00 PM	Area	Class	OK	Source
1232	14.14.2018 2:00:00 PM	Area	Class	OK	Source
1233	14.14.2018 2:00:00 PM	Area	Class	OK	Source
1234	14.14.2018 2:00:00 PM	Area	Class	OK	Source
1235	14.14.2018 2:00:00 PM	Area	Class	OK	Source
1236	14.14.2018 2:00:00 PM	Area	Class	OK	Source
1237	14.14.2018 2:00:00 PM	Area	Class	OK	Source
1238	14.14.2018 2:00:00 PM	Area	Class	OK	Source
1239	14.14.2018 2:00:00 PM	Area	Class	OK	Source
1240	14.14.2018 2:00:00 PM	Area	Class	OK	Source
1241	14.14.2018 2:00:00 PM	Area	Class	OK	Source
1242	14.14.2018 2:00:00 PM	Area	Class	OK	Source
1243	14.14.2018 2:00:00 PM	Area	Class	OK	Source
1244	14.14.2018 2:00:00 PM	Area	Class	OK	Source
1245	14.14.2018 2:00:00 PM	Area	Class	OK	Source
1246	14.14.2018 2:00:00 PM	Area	Class	OK	Source
1247	14.14.2018 2:00:00 PM	Area	Class	OK	Source
1248	14.14.2018 2:00:00 PM	Area	Class	OK	Source
1249	14.14.2018 2:00:00 PM	Area	Class	OK	Source
1250	14.14.2018 2:00:00 PM	Area	Class	OK	Source

PM-ANALYZE Message display

Function (continued)

Filter library

PM-ANALYZE offers a convenient filter library for backup of simple or hierarchical filter settings. Hierarchical filter settings with up to four levels facilitate faster localization of relevant messages. PM-ANALYZE determines the available filter values independently from the underlying database.

Configured filter settings can either be saved globally for all users or specifically for the user that is logged in.

The list of messages can be limited even further with the integrated quick search.

Analyses

The integrated statistical analysis functions which are conducted for the selected alarm log provide support in the analysis of errors or weak points. Messages are grouped with the optional grouping function and the analysis results are displayed in a clear structure.

- Frequency analysis**
 to determine the most frequently occurring messages; results can be listed by specifying grouping criteria, such as origin, for message columns. This way you expand the traditional range of a Top X analysis (number) to a technological Top X analysis (origin). A score is assigned according to the frequency with which a message occurs.
- Frequency analysis**
 to analyze the message traffic within a period of time, divided into smaller intervals to localize accumulations at a specific time; this way you can break down an entire month, for example, into days.
- Message duration analysis**
 determines the message duration of the archived messages.
- Flickering analysis**
 for localizing messages that occur very frequently within a short period of time (bursts) and then do not occur again for a longer period of time; such burst packets can be reliably determined with the flickering analysis by means of an adjustable threshold value.

Ordering data

Article No.

PM-ANALYZE Type S system software

Single-user/multi-user system server that runs on an interconnected WinCC system

9AE7112-1SS01-1AA0

PM-ANALYZE Type C system software

Multi-user system client that runs with system package Type S on an interconnected WinCC system or as thin client (without WinCC)

9AE7112-4SC01-1AA0

Note:

Additional PM-ANALYZE configurations available on request.

More information

Siemens AG
 Industrial Solutions and Services
 WinCC Competence Center Mannheim

Phone: +49 (0)621 456-3269
 Fax: +49 (0)621 456-3334

E-mail: WinCC.Competence@siemens.com

Additional information is available on the Internet at:

<http://www.siemens.com/process-management>

Class	Number	Alarm Count
01 Alarm	1000	19
02 Alarm	1000	17
03 Process message 101	1000	16
04 Alarm	1000	14
05 Process message 1011	1000	14
06 Process message 1011	1000	13
07 Alarm	1000	13
08 Process message 1001	1000	13
09 Process message 1001	1000	11

Alarm	Alarm ID	Alarm Description	Alarm Origin	Alarm Severity	Alarm Status	Alarm Category
00001	410420104	01041201.0001 ME	01.0000000	S	00	Process message
00002	410420104	01041201.0002 ME	01.0000000	S	00	Process message
00003	410420104	01041201.0003 ME	01.0000000	S	00	Process message
00004	410420104	01041201.0004 ME	01.0000000	S	00	Process message
00005	410420104	01041201.0005 ME	01.0000000	S	00	Process message
00006	410420104	01041201.0006 ME	01.0000000	S	00	Process message
00007	410420104	01041201.0007 ME	01.0000000	S	00	Process message
00008	410420104	01041201.0008 ME	01.0000000	S	00	Process message
00009	410420104	01041201.0009 ME	01.0000000	S	00	Process message
00010	410420104	01041201.0010 ME	01.0000000	S	00	Process message

PM ANALYZE Frequency

Premium Add-ons for SIMATIC WinCC

Notes

1. General Provisions

By using this catalog you can acquire hardware and software products described therein from Siemens AG subject to the following Terms and Conditions of Sale and Delivery (hereinafter referred to as "T&C"). Please note that the scope, the quality and the conditions for supplies and services, including software products, by any Siemens entity having a registered office outside Germany, shall be subject exclusively to the General Terms and Conditions of the respective Siemens entity. The following T&C apply exclusively for orders placed with Siemens Aktiengesellschaft, Germany.

1.1 For customers with a seat or registered office in Germany

For customers with a seat or registered office in Germany, the following applies subordinate to the T&C:

- for installation work the "General Conditions for Erection Works – Germany"¹⁾ ("Allgemeine Montagebedingungen – Deutschland" (only available in German at the moment)) and/or
- for Plant Analytics Services the "Standard Terms and Conditions for Plant Analytics Services – for Customer in Germany"¹⁾ ("Allgemeine Geschäftsbedingungen für das Plant Analytics Services – für Kunden in Deutschland" (only available in German at the moment)) and/or
- for stand-alone software products and software products forming a part of a product or project, the "General License Conditions for Software Products for Automation and Drives for Customers with a Seat or registered Office in Germany"¹⁾ and/or
- for other supplies and/or services the "General Conditions for the Supply of Products and Services of the Electrical and Electronics Industry"¹⁾.

In case such supplies and/or services should contain Open Source Software, the conditions of which shall prevail over the "General Conditions for the Supply of Products and Services of the Electrical and Electronics Industry"¹⁾.

A notice will be contained in the scope of delivery in which the applicable conditions for Open Source Software are specified. This shall apply mutatis mutandis for notices referring to other third party software components.

1.2 For customers with a seat or registered office outside Germany

For customers with a seat or registered office outside Germany, the following applies subordinate to the T&C:

- for Plant Analytics Services the "Standard Terms and Conditions for Plant Analytics Services"¹⁾ and/or
- for services the "International Terms & Conditions for Services"¹⁾ supplemented by "Software Licensing Conditions"¹⁾ and/or
- for other supplies of hard- and/or software the "International Terms & Conditions for Products"¹⁾ supplemented by "Software Licensing Conditions"¹⁾

1.3 For customers with master or framework agreement

To the extent our supplies and/or services offered are covered by an existing master or framework agreement, the terms and conditions of that agreement shall apply instead of T&C.

2. Prices

The prices are in € (Euro) ex point of delivery, exclusive of packaging.

The sales tax (value added tax) is not included in the prices. It shall be charged separately at the respective rate according to the applicable statutory legal regulations.

Prices are subject to change without prior notice. We will charge the prices valid at the time of delivery.

To compensate for variations in the price of raw materials (e.g. silver, copper, aluminum, lead, gold, dysprosium and neodym), surcharges are calculated on a daily basis using the so-called metal factor for products containing these raw materials.

A surcharge for the respective raw material is calculated as a supplement to the price of a product if the basic official price of the raw material in question is exceeded.

The metal factor of a product indicates the basic official price (for those raw materials concerned) as of which the surcharges on the price of the product are applied, and with what method of calculation.

An exact explanation of the metal factor can be downloaded at: www.siemens.com/automation/salesmaterial-as/catalog/en/terms_of_trade_en.pdf

To calculate the surcharge (except in the cases of dysprosium and neodym), the official price from the day prior to that on which the order was received or the release order was effected is used.

To calculate the surcharge applicable to dysprosium and neodym ("rare earths"), the corresponding three-month basic average price in the quarter prior to that in which the order was received or the release order was effected is used with a one-month buffer (details on the calculation can be found in the explanation of the metal factor).

3. Additional Terms and Conditions

The dimensions are in mm. In Germany, according to the German law on units in measuring technology, data in inches apply only to devices for export.

Illustrations are not binding.

Insofar as there are no remarks on the individual pages of this catalog - especially with regard to data, dimensions and weights given - these are subject to change without prior notice.

¹⁾ The text of the Terms and Conditions of Siemens AG can be downloaded at www.siemens.com/automation/salesmaterial-as/catalog/en/terms_of_trade_en.pdf

Appendix

Conditions of sale and delivery

4. Export regulations

We shall not be obligated to fulfill any agreement if such fulfillment is prevented by any impediments arising out of national or international foreign trade or customs requirements or any embargoes and/or other sanctions.

Export may be subject to license. We shall indicate in the delivery details whether licenses are required under German, European and US export lists.

Our products are controlled by the U.S. Government (when labeled with "ECCN" unequal "N") and authorized for export only to the country of ultimate destination for use by the ultimate consignee or end-user(s) herein identified. They may not be resold, transferred, or otherwise disposed of, to any other country or to any person other than the authorized ultimate consignee or end-user(s), either in their original form or after being incorporated into other items, without first obtaining approval from the U.S. Government or as otherwise authorized by U.S. law and regulations.

The export indications can be viewed in advance in the description of the respective goods on the Industry Mall, our online catalog system. Only the export labels "AL" and "ECCN" indicated on order confirmations, delivery notes and invoices are authoritative.

Products labeled with "AL" unequal "N" are subject to European/national export authorization. Products without label, with label "AL:N" / "ECCN:N", or label "AL:9X9999" / "ECCN: 9X9999" may require authorization from responsible authorities depending on the final end-use, or the destination.

If you transfer goods (hardware and/or software and/or technology as well as corresponding documentation, regardless of the mode of provision) delivered by us or works and services (including all kinds of technical support) performed by us to a third party worldwide, you must comply with all applicable national and international (re-)export control regulations.

If required for the purpose of conducting export control checks, you (upon request by us) shall promptly provide us with all information pertaining to the particular end customer, final disposition and intended use of goods delivered by us respectively works and services provided by us, as well as to any export control restrictions existing in this relation.

The products listed in this catalog may be subject to European/German and/or US export regulations. Any export requiring approval is therefore subject to authorization by the relevant authorities.

Errors excepted and subject to change without prior notice.

Further information can be obtained from our branch offices listed at www.siemens.com/automation-contact

Interactive Catalog on DVD	<i>Catalog</i>	Process Instrumentation and Analytics	<i>Catalog</i>
Products for Automation and Drives	CA 01	<i>Digital: Field Instruments for Process Automation</i>	FI 01
Building Control		<i>Digital: Display Recorders SIREC D</i>	MP 20
GAMMA Building Control	ET G1	<i>Digital: SIPART Controllers and Software</i>	MP 31
Drive Systems		Products for Weighing Technology	WT 10
SINAMICS G130 Drive Converter Chassis Units	D 11	<i>Digital: Process Analytical Instruments</i>	AP 01
SINAMICS G150 Drive Converter Cabinet Units		<i>Digital: Process Analytics, Components for Continuous Emission Monitoring</i>	AP 11
SINAMICS GM150, SINAMICS SM150 Medium-Voltage Converters	D 12	Low-Voltage Power Distribution and Electrical Installation Technology	
<i>Digital: SINAMICS PERFECT HARMONY GH180 Medium-Voltage Air-Cooled Drives (Germany Edition)</i>	D 15.1	SENTRON · SIVACON · ALPHA Protection, Switching, Measuring and Monitoring Devices, Switchboards and Distribution Systems	LV 10
SINAMICS G180 Converters – Compact Units, Cabinet Systems, Cabinet Units Air-Cooled and Liquid-Cooled	D 18.1	Standards-Compliant Components for Photovoltaic Plants	LV 11
SINAMICS S120 Chassis Format Converter Units	D 21.3	Electrical Components for the Railway Industry	LV 12
SINAMICS S120 Cabinet Modules		Power Monitoring Made Simple	LV 14
SINAMICS S150 Converter Cabinet Units		Components for Industrial Control Panels according to UL Standards	LV 16
SINAMICS S120 and SIMOTICS	D 21.4	3WT Air Circuit Breakers up to 4000 A	LV 35
SINAMICS DCM DC Converter, Control Module	D 23.1	3VT Molded Case Circuit Breakers up to 1600 A	LV 36
SINAMICS Inverters for Single-Axis Drives · Built-In Units	D 31.1	<i>Digital: SIVACON System Cubicles, System Lighting and System Air-Conditioning</i>	LV 50
SINAMICS Inverters for Single-Axis Drives · Distributed Inverters	D 31.2	<i>Digital: ALPHA Distribution Systems</i>	LV 51
<i>Digital: SINAMICS S210 Servo Drive System</i>	D 32	ALPHA FIX Terminal Blocks	LV 52
<i>Digital: SINAMICS V90 Basic Servo Drive System</i>	D 33	SIVACON S4 Power Distribution Boards	LV 56
<i>Digital: SINAMICS G120P and SINAMICS G120P Cabinet pump, fan, compressor converters</i>	D 35	SIVACON 8PS Busbar Trunking Systems	LV 70
LOHER VARIO High Voltage Motors Flameproof, Type Series 1PS4, 1PS5, 1MV4 and 1MV5 Frame Size 355 to 1000, Power Range 80 to 7100 kW	D 83.2	<i>Digital: DELTA Switches and Socket Outlets</i>	ET D1
<i>Digital: Three-Phase Induction Motors SIMOTICS HV, SIMOTICS TN</i>	D 84.1	Vacuum Switching Technology and Components for Medium Voltage	HG 11.01
<i>Digital: Three-Phase Induction Motors SIMOTICS HV</i>	D 84.3	Motion Control	
High Voltage Three-phase Induction Motors	D 84.9	SINUMERIK 840 Equipment for Machine Tools	NC 62
SIMOTICS HV Series A-compact PLUS		SINUMERIK 808 Equipment for Machine Tools	NC 81.1
<i>Digital: Modular Industrial Generators SIGENTICS M</i>	D 85.1	SINUMERIK 828 Equipment for Machine Tools	NC 82
Three-Phase Induction Motors SIMOTICS HV, Series H-compact	D 86.1	SIMOTION Equipment for Production Machines	PM 21
Synchronous Motors with Permanent-Magnet Technology, HT-direct	D 86.2	<i>Digital: Drive and Control Components for Cranes</i>	CR 1
DC Motors	DA 12	Power Supply	
SIMOVERT PM Modular Converter Systems	DA 45	SITOP Power supply	KT 10.1
MICROMASTER 420/430/440 Inverters	DA 51.2	Safety Integrated	
MICROMASTER 411/COMBIMASTER 411	DA 51.3	Safety Technology for Factory Automation	SI 10
Low-Voltage Three-Phase-Motors		SIMATIC HMI / PC-based Automation	
SIMOTOCS S-1FG1 Servo geared motors	D 41	Human Machine Interface Systems/ PC-based Automation	ST 80/ ST PC
SIMOTICS Low-Voltage Motors	D 81.1	SIMATIC Ident	
SIMOTICS FD Low-Voltage Motors	D 81.8	Industrial Identification Systems	ID 10
LOHER Low-Voltage Motors	D 83.1	SIMATIC Industrial Automation Systems	
<i>Digital: MOTOX Geared Motors</i>	D 87.1	Products for Totally Integrated Automation	ST 70
SIMOGEAR Geared Motors	MD 50.1	SIMATIC PCS 7 Process Control System System components	ST PCS 7
SIMOGEAR Electric-monorail geared motors	MD 50.8	SIMATIC PCS 7 Process Control System Technology components	ST PCS 7 T
Light-load and heavy-load applications		Add-ons for the SIMATIC PCS 7 Process Control System	ST PCS 7 AO
SIMOGEAR Gearboxes with adapter	MD 50.11	SIMATIC S7-400 advanced controller	ST 400
Mechanical Driving Machines		SIMATIC NET	
FLENDER Standard Couplings	MD 10.1	Industrial Communication	IK PI
FLENDER High Performance Couplings	MD 10.2	SIRIUS Industrial Controls	
FLENDER Backlash-free Couplings	MD 10.3	<i>Digital: SIRIUS Industrial Controls</i>	IC 10
FLENDER SIP Standard industrial planetary gear units	MD 31.1	Information and Download Center	

Digital: These catalogs are only available as a PDF.

Digital versions of the catalogs are available on the Internet at: www.siemens.com/industry/infocenter
 There you'll find additional catalogs in other languages.
 Please note the section "Downloading catalogs" on page "Online services" in the appendix of this catalog.

Siemens AG
Digital Factory Division
Postfach 48 48
90026 Nürnberg
Germany

© Siemens AG 2018
Subject to change without prior notice
PDF (E86060-K4680-B211-B3-7600)
KG 0718 PDF 32 En
Produced in Germany

The information provided in this catalog contains descriptions or characteristics of performance which in case of actual use do not always apply as described or which may change as a result of further development of the products. An obligation to provide the respective characteristics shall only exist if expressly agreed in the terms of contract. Availability and technical specifications are subject to change without notice.

All product designations may be trademarks or product names of Siemens AG or supplier companies whose use by third parties for their own purposes could violate the rights of the owners.

Security information

Siemens provides products and solutions with industrial security functions that support the secure operation of plants, systems, machines and networks.

In order to protect plants, systems, machines and networks against cyber threats, it is necessary to implement – and continuously maintain – a holistic, state-of-the-art industrial security concept. Siemens' products and solutions only form one element of such a concept.

Customer is responsible to prevent unauthorized access to its plants, systems, machines and networks. Systems, machines and components should only be connected to the enterprise network or the internet if and to the extent necessary and with appropriate security measures (e.g. use of firewalls and network segmentation) in place.

Additionally, Siemens' guidance on appropriate security measures should be taken into account. For more information about industrial security, please visit <http://www.siemens.com/industrialsecurity>.

Siemens' products and solutions undergo continuous development to make them more secure. Siemens strongly recommends to apply product updates as soon as available and to always use the latest product versions. Use of product versions that are no longer supported, and failure to apply latest updates may increase customer's exposure to cyber threats.

To stay informed about product updates, subscribe to the Siemens Industrial Security RSS Feed under <http://www.siemens.com/industrialsecurity>.